

TECHNICAL MANUAL

OPERATOR'S, ORGANIZATIONAL, DIRECT SUPPORT,
AND GENERAL SUPPORT MAINTENANCE MANUAL

SIGNAL GENERATORS SG-299/U

(NSN 6625-00-624-3516),

SG-299A/U (NSN 6625-00-897-0060),

SG-299B/U (NSN 6625-00-808-5584),

SG-299C/U (NSN 6625-00-916-8541),

SG-299D/U (NSN 6625-00-765-6656),

AND SG-299E/U

HEADQUARTERS, DEPARTMENT OF THE ARMY

JUNE 1975

WARNING

Hazardous voltages are used in the operation of this equipment. Use extreme caution not to contact high-voltage 115V or 230V input connections when working on equipment. When working inside the equipment, always disconnect primary power, and ground the high-voltage capacitors. Failure to comply may result in serious injury or death to personnel.

CHANGE }
No. 1 }

HEADQUARTERS
DEPARTMENT OF THE ARMY
WASHINGTON, DC, 20 May 1976

**Operator's, Organizational, Direct Support, and
General Support Maintenance Manual
SIGNAL GENERATORS SG-299/U (NSN 662500-624-3516)
SG-299A/U (NSN 6625-00-897-0060)
SG-299B/U (NSN 6625-00-808-5584)
SG-299C/U (NSN 6625-00-916-8541)
SG-299D/U (NSN 6625-00-765-6656)
AND SG-299E/U**

TM 11-6625-258-14, 13 June 1975, is changed as follows:

1. New or changed material is indicated by a vertical bar in the margin of the page.
2. Remove and insert pages as indicated in the page list below:

<i>Remove pages</i>	<i>Insert pages</i>
1-1 and 1-2	1-1 and 1-2
6-33 through 6-36	6-33 through 6-36
3. File this change sheet in front of the manual for reference purposes.

By Order of the Secretary of the Army:

FRED C. WEYAND
*General, States Army
Chief of Staff*

Official:

PAUL T. SMITH
*Major General, United States Army
The Adjutant General*

Distribution:

Active Army:

USASA (2)	Ft Huachuca (10)	USAERDAA (1)	29-134
COE (1)	Ft Gillem (10)	USAERDAW (1)	29-136
TSG (1)	Ft Carson (5)	Sig FLDMS (1)	37
USAARENBD (1)	SAAD (30)	Units org under fol TOE (1 ea.):	44-235
DARCOM (1)	LBAD (14)	7	44-236
MICOM (2)	TOAD (1-1)	11-16	44-236
TECOM (2)	SHAD (3)	11-117	44-568
ARDCOM (2)	HISA (Ft Monmouth) (33)	11-500(AA-AC)	
ARADCOM Rgm (2)	Svc Colleges (1)	17	
OS Maj Comd (4)	USASESS (5)	29-1	
LOGCOMD (3)	USAINTC (3)	29-11	
USACC (4)	USAADS (2)	29-15	
USACC-CONUS(2)	USAFAS (2)	29-16	
MDW (1)	USAARMS (2)	29-21	
Armies (2)	USAIS (2)	29-25	
Corps (2)	USAES (2)	29-35	
Instl (2) except	MAAG (1)	29-36	
Ft Gordon (10)	USARMIS (1)	29-56	

ARNG: State AG (3).

USAR: None.

For explanation of abbreviations used, see AR 310-50.

**Operator's, Organizational, Direct Support,
 and General Support Maintenance Manual**

**SIGNAL GENERATORS SG-299/ U (NSN 6625-00-624-3516),
 SG-299A / U (N SN 6625-00-897-0060),
 SG-299B / U (NSN 6625-00-808-5584) ,
 SG-299C / U (NSN 6625-00-916-8541) ,
 SG-299D / U (NSN 6625-00-765-6656),
 AND SG-299E / U**

		Paragraph	Page
CHAPTER	1. INTRODUCTION		
Section	I. General.....	1-1-1-6	1-1
	II. Description and data.....	1-7-1-12	1-1
CHAPTER	2. SERVICE UPON RECEIPT OF EQUIPMENT AND INSTALLATION.....	2-1-2-4	2-1
Section	3. OPERATING INSTRUCTIONS		
	I. Controls and instruments.....	3-1,3-2	3-1
	II. Operation under usual conditions.....	3-3-3-6	3-3
	III. Operation under unusual conditions.....	3-7-3-9	3-5
CHAPTER	4. OPERATOR AND ORGANIZATIONAL MAINTENANCE INSTRUCTIONS		
Section	I. Operator and organizational tools and equipment.....	4-1-4-3.	4-1
	II. Preventive maintenance checks and services.....	4-4-4-10	4-1
	III. Troubleshooting.....	4-11-4-13	4-4
CHAPTER	5. FUNCTIONING OF EQUIPMENT.....	5-1-5-8	5-1
Section	6. GENERAL SUPPORT MAINTENANCE		
	I. General.....	6-1,6-2	6-1
	II. General support tools and test equipment.....	6-3 6-4	6-1
	III. Troubleshooting.....	6-5-6-9	6-1
	IV. Maintenance of the signal generator.....	6-10-6-16	6-21
	V. General support testing procedures.....	6-17-6-29	6-27
APPENDIX	A. REFERENCES.....		A-1
	B. BASIC ISSUE ITEMS LIST (BILL) AND ITEMS TROOP INSTALLED OR AUTHORIZED LIST (ITIAL) (not applicable)		
Section	C. MAINTENANCE ALLOCATION		
	I. I. Introduction.....		C-1
	II. Maintenance allocation chart.....		C-3
INDEX		Index 1

*This manual supersedes TM 11-5134-15, 14 May 1958, including all changes.

LIST OF ILLUSTRATIONS

<i>Number</i>	<i>Title</i>	<i>Page</i>
1-1	Signal Generator SG-229(*)/U.	1-0
2-1	Typical packaging diagram.	2-1
3-1	Signal Generator SG-299/U, controls and indicators.	3-2
3-2	Test setup.	3-4
3-3	Impedance matching networks.	3-5
4-1	Fan motor oilhole locations.	4-3
4-2	Signal Generator SG-299/U, SG-299B/U, SG-299C/U, SG-299D/U, and SG-299E/U, tube location.	4-5
4-3	Signal Generator SG-299A/U, tube locations.	4-6
5-1	Signal Generator SG-299(*)/U, block diagram.	5-2
5-2	Multivibrator circuit, simplified schematic diagram.	5-4
5-3	RANGE switch schematic diagram.	5-5
5-4	Sync trigger circuit, simplified schematic diagram.	5-6
5-5	Clipper amplifier circuit, simplified schematic diagram.	5-8
5-6	Power amplifier circuit, simplified schematic diagram.	5-9
5-7	Attenuator switch schematic diagram.	5-10
5-8	Power supply circuit (SG-299/U model), simplified schematic diagram.	5-11
6-1	Tube socket voltage and resistance diagram (unlettered, B, D, and E models).	6-3
6-2	Tube socket voltage and resistance diagram (A and C models).	6-4
6-3	Signal Generator SG-299/U, parts location, top view.	6-8
6-4	Signal Generator SG-299A/U, adjustments.	6-9
6-5	Signal Generator SG-299/U, parts location, bottom view.	6-10
6-6	Signal Generator SG-299A/U, parts location, bottom view.	6-11
6-7	Signal Generator SG-299A/U (Order No. 4502-PP-60) and SG-299C/U, parts location, bottom view.	6-12
6-8	Signal Generator SG-299B/U, SG-299D/U, and SG-299E/U, parts location, bottom view, part 1.	6-13
6-9	Signal Generator SG-299B/U and SG-299D/U, and SG-299E/U, parts location, bottom view, part 2.	6-14
6-10	Signal Generator SG-299A/U, parts location, side view.	6-15
6-11	Signal Generator SG-299A/U, parts location, terminal board.	6-16
6-12	Signal Generator SG-299A/U sync trigger and multivibrator chassis, parts location, top view.	6-17
6-13	Signal Generator SG-299B/U, SG-299D/U, and SG-299E/U sync trigger and multivibrator chassis, parts location, left side view.	6-18
6-14	Signal Generator SG-299B/U, SG-299D/U, SG-299E/U sync trigger and multivibrator chassis, parts location, right side view.	6-19
6-15	Waveforms use with troubleshooting table.	6-20
6-16	Signal Generator SG-299/U, location of adjustment controls.	6-23
6-17	Signal Generator SG-299B/U, SG-299D/U, and SG-299E/U, location of adjustment controls.	6-24
6-18	Frequency adjustment test setup.	6-25
6-19	Symmetrical and nonsymmetrical waveforms.	6-25
6-20	External synchronization sensitivity test setup.	6-26
6-21	Symmetry test setup.	6-30
6-22	Low impedance output voltage test setup.	6-32
6-23	High impedance output voltage test setup.	6-34
6-24	Low impedance output attenuation test setup.	6-36
6-25	External synchronization test setup.	6-38
6-26	Frequency range tracking test setup.	6-40
6-27	Output amplitude, line voltage variation test setup.	6-44
6-28	Output frequency, line voltage variation test setup.	6-46
FO-1	Color code marking MIL-STD resistors, inductors, and capacitors.	
FO-2	Signal Generator, sync trigger and multivibrator, schematic diagram.	
FO-3	Signal Generator, amplifier stages, schematic diagram.	
FO-4	Signal Generator SG-299/U, power supply, schematic diagram.	
FO-5	Signal Generator SG-299A/U, power supply, schematic diagram.	
FO-6	Signal Generator SG-299B/U, SG-299C/U, SG-299D/U, and SG-299E/U, power supply, schematic diagram.	

LIST OF TABLES

Number	<i>Title</i>	<i>Page</i>
3-1	Operator Controls, Indicators, and Connectors	3-3
4-1	Operator/Crew Preventive Maintenance Checks and Services	4-2
4-2	Organizational Preventive Maintenance Checks and Services (Monthly).	4-2
4-3	Organizational Preventive Maintenance Checks and Services (Quarterly).	4-3
4-4	Organizational Troubleshooting.	4-4
4-5	Adjustments Following Tube Replacements.	4-6
6-1	Short Circuit Tests.	6-5
6-2	Troubleshooting	6-5
6-3	Resistances of Transformer Windings and Coils.	6-21
6-4	Physical Tests and Inspections.	6-28
6-5	Symmetry Test.	6-31
6-6	Low Impedance Output Voltage Test.	6-33
6-7	High Impedance Output Voltage Test.	6-35
6-8	Low Impedance Output Attenuation Test.	6-37
6-9	External Synchronization Test.	6-39
6-10	Frequency Range Tracking Test.	6-41
6-11	Output Amplitude, Line Voltage Variation Test.	6-45
6-12	Output Frequency, Line Voltage Variation Test.	6-47

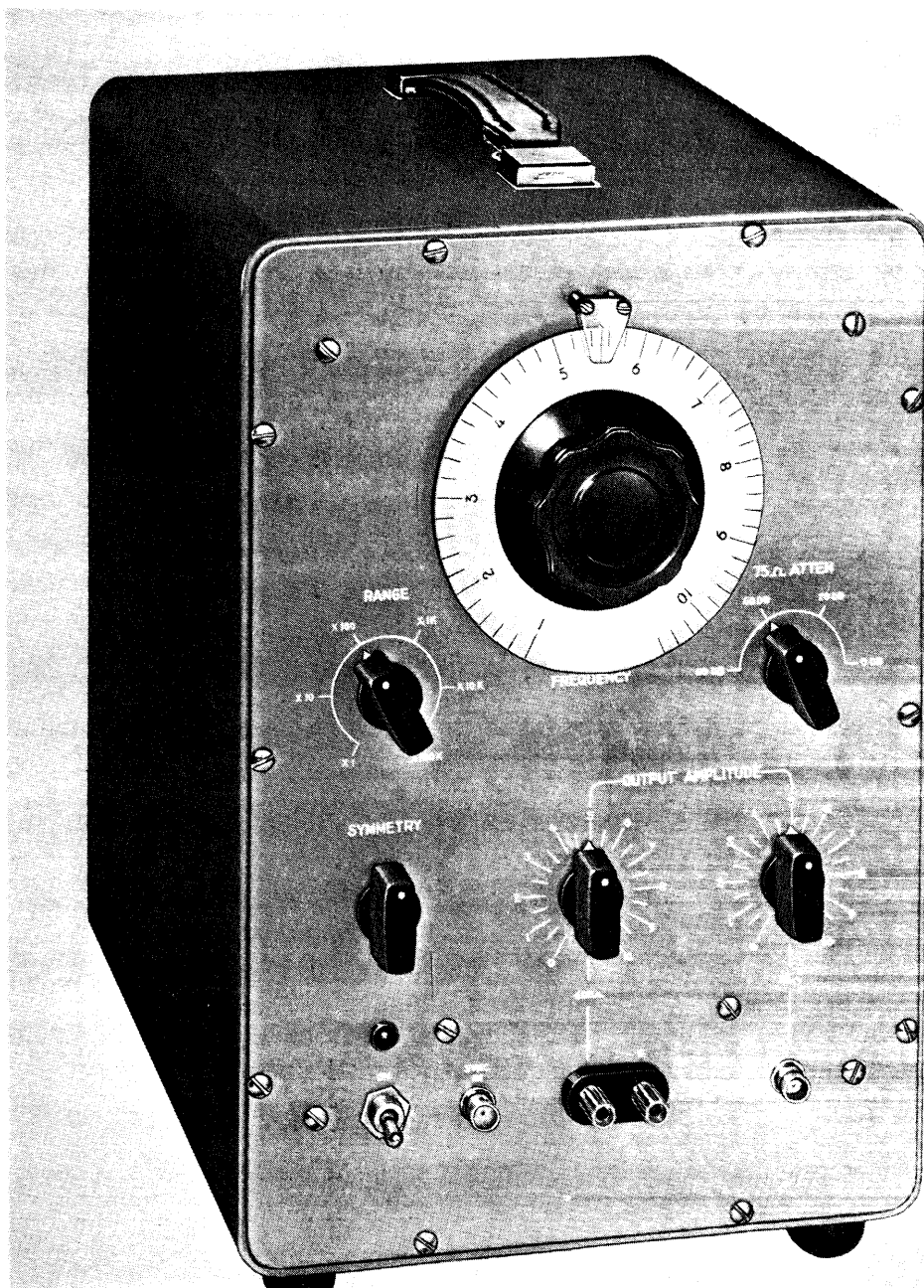

EL6625-258-14--TM-I

Figure 1-1. Signal Generator SB-299(*)/U.

CHAPTER 1

INTRODUCTION

Section I. GENERAL

1-1. Scope

a. This manual describes Signal Generator SG - 299(*)/U and provides instructions for installation, operation, and operator, organizational, and general support maintenance. No direct support maintenance is authorized for this equipment. Figure 1-1 illustrates model SG - 299/U; all other models are similar.

b. Official nomenclature followed by (*) is used to indicate all models of the equipment covered in this manual. This Signal Generator SG-299(*)/U represents Signal Generator SG-299/U, SG - 299A/U, SG-299B/U, SG-299C/U, SG-299D/U, and SG-299E/U. Information in this manual applies to all models unless otherwise specified.

c. A list of references is contained in appendix A.

d. A maintenance allocation chart (MAC) is contained in appendix C.

1-2. Indexes of Publications

a. *DA Pam 310-4*. Refer to the latest issue of DA Pam 310-4 to determine whether there are new editions, changes, or additional publications pertaining to the equipment.

b. *DA Pam 310-7*. Refer to DA Pam 310-7 to determine whether there are modification work orders (M WO'S) pertaining to the equipment.

1-3. Forms and Records

a. *Reports of Maintenance and Unsatisfactory Equipment*. Maintenance forms, records, and reports which are to be used by maintenance personnel at all maintenance levels are listed in and prescribed by TM 38-750.

b. *Report of Packaging and Handling Deficiencies*. Fill out and forward DD Form 6 (Packaging Improvement Report) as prescribed in AR 700-58/NAVSUPINST 4030.29/AFR 71.13/MCO P4030.29A, and DSAR 4145.8.

c. *Discrepancy in Shipment Report (DISREP (SF 361))*. Fill out and forward Discrepancy in Shipment Report (DISREP) (SF 361) as prescribed in AR 55-38 /NAVSUPINST 4610.33 A/AFR75-18/MCO P4610.19B, and DSAR 4500.15.

1-4. Reporting of Errors

The reporting of errors, omissions, and recommendations for improving this publication by the individual user is encouraged. Reports should be submitted on DA Form 2028 [Recommended Changes to Publications and Blank Forms] and forwarded direct to Commander, US Army Electronics Command, ATTN: AMSEL-MA-Q, Fort Monmouth, NJ 07703.

1-5. Administrative Storage

The procedures for administrative storage are outlined in TM 740-90-1; however, the exact procedure in repacking for limited storage depends on the materials available and the condition under which the equipment is to be stored.

1-6. Destruction of Army Materiel to Prevent Enemy Use

Refer to TM 750-244-2 for destruction procedures for electronic equipment. Demolition and destruction will be under the direction of the commander.

Section II. DESCRIPTION AND DATA

1-7. Purpose and Use

Signal Generator SG-299(*)/U is a wide-range (1 Hz to 1 MHz), squarewave generator. It is used with an oscilloscope to determine the frequency response and phase shift characteristics of video and audio amplifiers. Amplifier gain measurements may also be made with this

equipment. Signal Generator SG-299(*)/U will be referred to as signal generator throughout this manual.

1-8. Description

a. This equipment consists of the signal generator (fig. 1-1) and running spares. The

signal generator, which is self-contained, is housed in a portable case with a carrying handle. The power cable is permanently attached next to the fuse receptacle at the right rear corner of the signal generator. A pilot lamp on the front panel indicates when the signal generator is energized.

b. All operating controls are on the front panel.

c. Individual connectors, along the lower edge of the front panel, are provided for 75-ohm output, 600-ohm output, and the external synchronizing (sync) input connections.

1-9. Items Comprising an Operable Equipment Signal Generator SG-299(*)/U (FSN 6625-00-621-3516) comprises an operable equipment.

1-10. Additional Equipment Required

The test applications of the signal generator require the use of other equipment, as follows:

a. *Oscilloscope and Audio Oscillator.* An oscilloscope is required for visual display of test results. A source of external synchronizing signal voltage, such as an audio oscillator, is necessary in certain types of operation to trigger the sync input circuit of the signal generator. Typical equipments suitable for use with the signal generator are Oscilloscope AN/USM-281A and Signal Generator AN /U RM-127.

b. *Cable Assemblies.* Suitable cable assemblies for interconnecting the signal generator with other equipments must be provided. The types of cable assemblies needed will vary according to the type of operation and the design of the associated equipments. Connectors on the signal generator panel are coaxial BNC type for the sync input and low impedance (75 ohms) output, and banana jack binding posts for the high impedance (600 ohms) output.

1-11. Differences in Models

AU models of the signal generator are similar to each other except for the following differences:

a. Models SG-299A/U, SG-299B/U, SG-299C/U, SG/299D/U, and SG-299E/U use standard wiring. The SG-299/U uses printed circuits.

b. The methods of converting the signal generator to 230-volt, 60-Hz operation are different. See paragraph 6-15 for exact instructions.

c. The tube locations on both upper and lower decks are different (fig. 4-2 and 4-3).

d. The locations of the adjustment controls are different (fig. 6-3 and 6-4).

e. In the SG-299/U model, the OUTPUT AMPLITUDE 75 ohms and 600 ohms controls are graduated from O through 10. The A, B, C, D, and E models have the OUTPUT A.M. PLITUDE- 600 ohms control graduated from O through 60, and the OUTPUT AMPLITUDE- 75 ohms control graduated from O through 7.

f. The voltage and resistance values at some of the tube sockets are different (fig. 6-1 and 6-2).

g. The C, D, and E models have a line filter added across the ac, powerline (fig. FO-6).

1-12. Tabulated Data

Frequency range:	
x 1	1 to 10 Hz
X10	10 to 100 Hz
X100	100 to 1000 Hz
X1K	1 kHz to 10 kHz
X10K	10 kHz to 100 kHz
X100K	100 kHz to 1 MHz
Types of output:	
75 Ω impedance output	7.0 volts peak to peak. 75 ohms internal impedance. 0.02-microsecond rise time.
600Ω impedance output	55 volts peak to peak. 600 ohms internal impedance. 0.1 -microsecond rise time.
Types of input:	
Sync input	Positive-going signal pulse or sine wave, as determined by external equipment being used.
Amplitude of sync input signal:	
Recommended peak	5 volts
Recommended minimum	3 volts.
Power supply requirements:	
Line. voltage input	115 volts ac, 50 to 60 Hz or 230 volts ac, 50 to 60 Hz.
Power consumption	210 watts.

CHAPTER 2

SERVICE UPON RECEIPT OF EQUIPMENT AND INSTALLATION

2-1. Unpacking

a. *Packaging Data.* When packed for shipment, the signal generator and running spares are

placed in a single carton and packed in a wire bound crate. An exploded view of the method of packing is shown in figure 2-I.

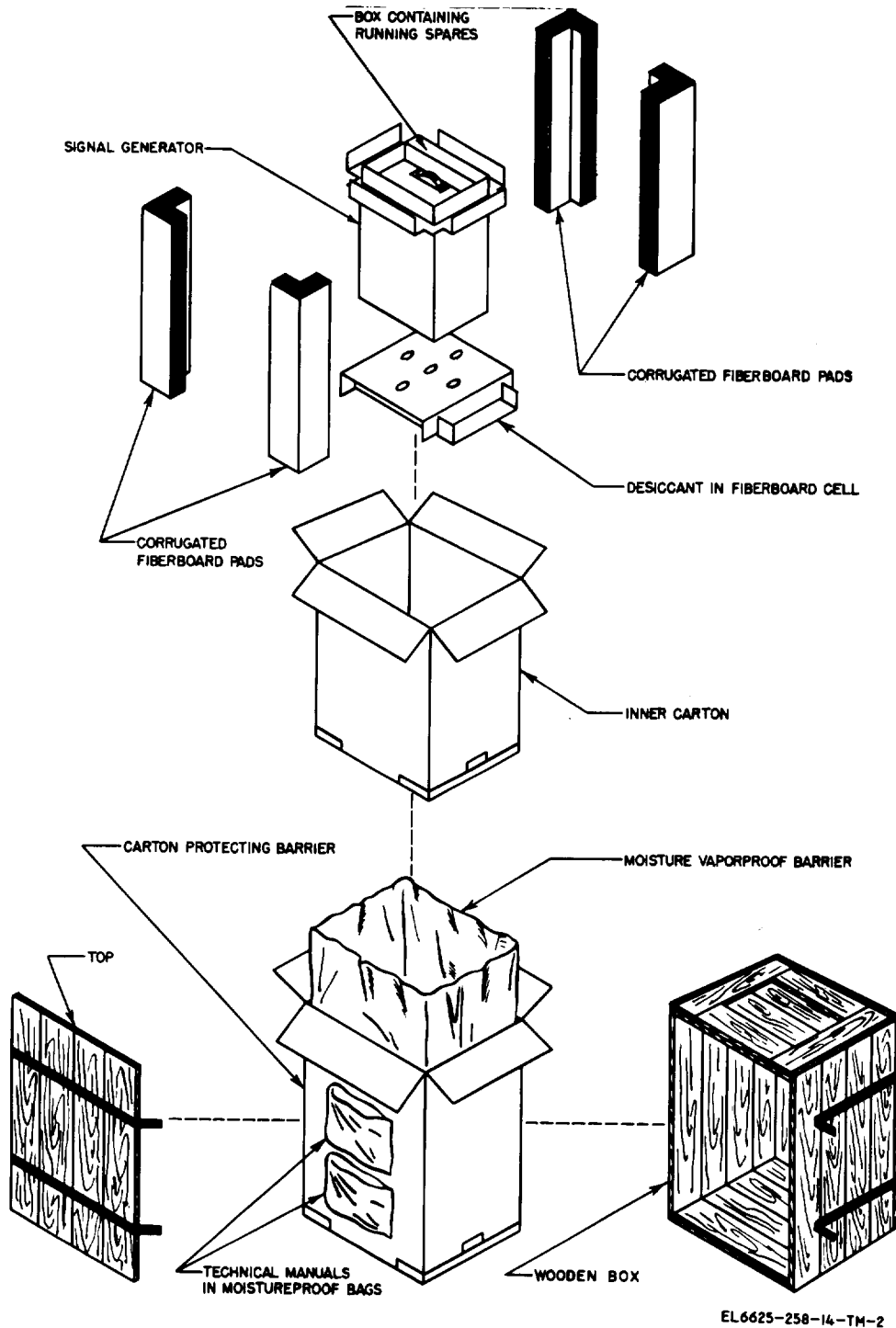

Figure 2-1 Typical packaging diagram

b. Unpacking Procedure. Remove contents of packing crate as follows:

- (1) Cut and fold back metal straps.

CAUTION

Do not attempt to pry off crate sides or top. Failure to comply may result in damage to equipment.

- (2) Remove nails from top of box with nail puller.

- (3) Remove top.

- (4) Remove envelope containing manual.

- (5) Remove outer waterproof carton.

- (6) Open outer waterproof carton and remove inner carton that is wrapped in moisture-vaporproof barrier.

- (7) Open moisture-vaporproof barrier and open inner tray of inner carton.

- (8) Remove running spares which are packaged in the top tray of inner carton.

2-2. Checking Unpacked Equipment

a. Inspect equipment for damage incurred during shipment. If equipment has been damaged, report the damage on DD Form 6 (para 1-3 *b*).

b. See that the equipment is completed as listed on packing slip. If a packing slip is not

available, check the equipment against the data given in paragraph 1-9. Report all discrepancies in accordance with TM 38-760. Shortage of a minor assembly or part that does not affect proper functioning of the equipment should not prevent use of the equipment.

c. If the equipment has been used or reconditioned, see whether it has been changed by a modification work order (MWO). If the equipment has been modified, the MWO number will appear on the front panel near the nomenclature plate. Check to see whether any operational instruction changes resulting from currently applicable MWO's have been entered in the equipment manual. (Current MWO's applicable to the equipment are listed in DA Pam 310-7.)

2-3. Installation of Equipment

Install the signal generator at any convenient location near an appropriate power source. The location should not expose equipment to moisture or excessive vibration.

2-4. Power Conversion

Determine the power source to be used and perform conversion per instructions given in paragraph 6-15.

CHAPTER 3

OPERATING INSTRUCTIONS

Section I. CONTROLS AND INSTRUMENTS

3-1. **General**

Before operating the signal generator the operator must become thoroughly familiar with the controls and indicators. Do not operate until the location, function, and use of each control, indicator, and connector are understood.

3-2. Operator Controls

Locations of the operator controls, indicators,

and connectors are shown in figure 3-1. Figure 3-1 illustrates model SG-299/U only. All other models are identical with the exception of the OUTPUT AMPLITUDE control graduations. Table 3-1 provides information on the function of each control, indicator, and connector.

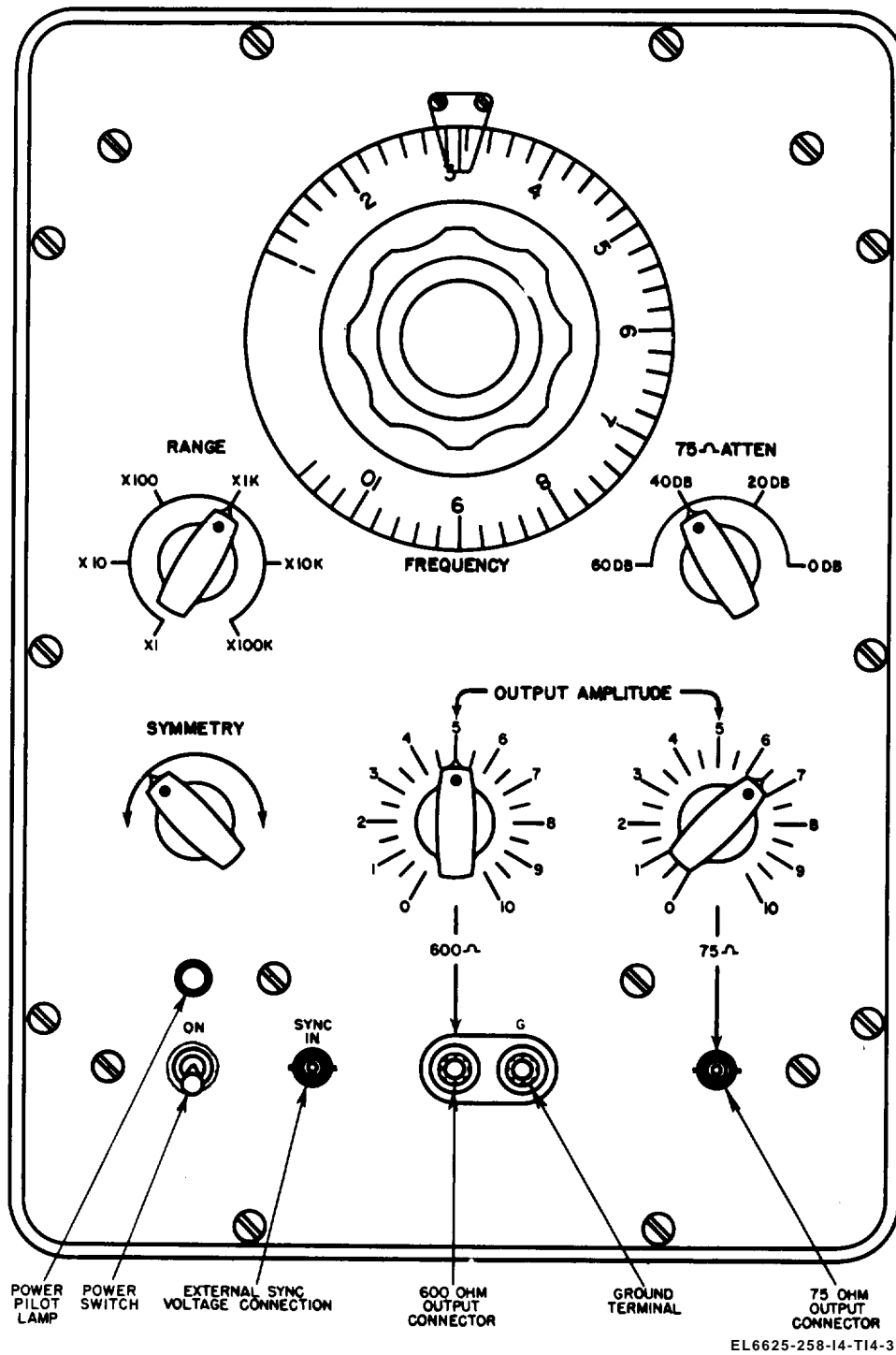

Figure 3-1. Signal Generator, SG-299/U, controls and indicators,

Table 3-1. Operator Controls, Indicators, and Connectors

<i>Control, indicator, or connector</i>	<i>Function</i>
FREQUENCY control	Tunes frequency within frequency band determined by RANGE switch.
RANGE switch.	Selects one of six frequency bands to be covered by FREQUENCY control.
SYMMETRY control.	Adjusts symmetry of square wave output.
Power ON pilot lamp.....	Lights when power is applied to signal generator.
Power ON switch....	Applies power to signal generator.
OUTPUT AMPLITUDE 600Ω control	Adjusts amplitude of signal output at 600-ohm output connector.
OUTPUT AMPLITUDE 75 Ω control.	Adjusts amplitude of signal output at 75.ohm connector.
75 Ω ATTEN switch.	Attenuates signal at 75-ohm output connector in 20-dB steps.
SYNC IN connector	Input connector for external sync signal.
6000 output connector.	High impedance output corrector.
G binding post	Ground terminal.
75 Ω output connector.	Low impedance output.

Section II. OPERATION UNDER USUAL CONDITIONS

3-3. Types of Operations

a. Two types of operation are possible with the signal generator: free running and synchronized.

(1) *Free running.* The internal multivibrator operates at a frequency determined by the FREQUENCY control and the RANGE switch.

(2) *Synchronized* The internal multivibrator operates at a frequency determined by an external signal applied to the SYNC IN connector.

b. Two individual output voltages are provided by the signal generator— the 600-ohm and the 75-ohm outputs. Each output is available at its respective output connector. It is possible to use these outputs either individually or simultaneously and with either type of operation described in a (1) and (2) above.

c. For either type of operation, perform the following procedures:

- (1) Starting procedure (para 3-4).
- (2) Operating procedure (para 3-5).
- (3) Stopping procedure (para 3-6).

3-4. Starting Procedure

a. Connect line cord plug to power source of 115 or 230 volts ac at 50 to 60 Hz, depending upon the internal power supply connections. (Refer to para 6-15 for conversion instructions.)

b. Set power switch to ON, When pilot lamp

lights, the signal generator will be ready for operation after a 5-minute warmup,

3-5. Operating Procedure

a. *Free Running Operation.*

(1) Set RANGE selector switch to multiplier position for the range of frequencies to be used.

(2) Adjust FREQUENCY control to desired frequency of operation.

NOTE

The frequency control dial is divided into ten main divisions numbered 1 through 10. Each main division is divided into five equal subdivisions. The frequency of operation in Hz is obtained by multiplying the dial reading under the index line by the multiplier number indicated by the RANGE selector.

(3) Determine whether the 600-ohm and/or 75-ohm output is to be used for the equipment to be tested. This will be governed by the nature of the tests to be made and the characteristic impedance of the equipment.

(4) Connect signal generator to vertical input of oscilloscope as shown in figure 3-2. Either the 75-ohm output or the 600-ohm output may be used.

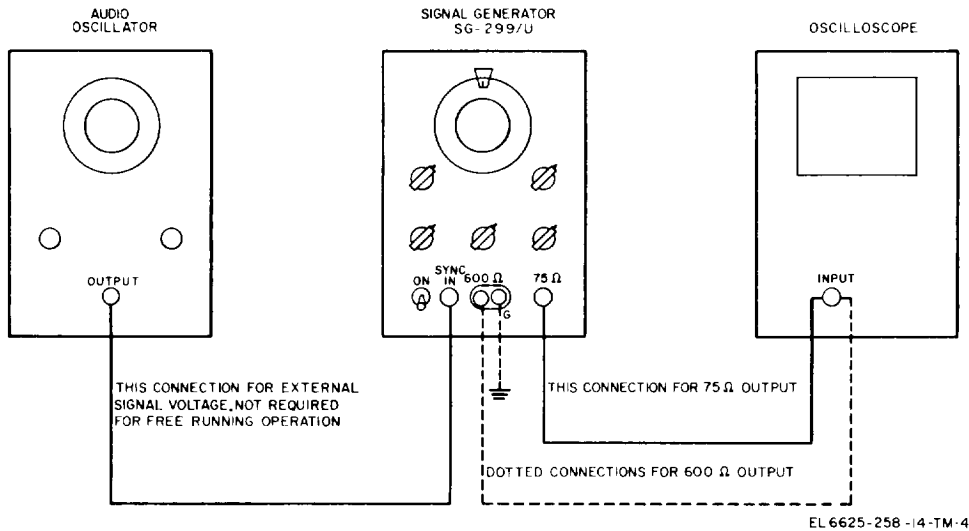

Figure 3-2 Test setup.

(5) Turn on both the signal generator and the oscilloscope and allow 5 minutes to warm up. Adjust horizontal sweep of oscilloscope for two or three cycles of output waveform.

(6) Adjust symmetry control of signal generator for equal widths of pulses as viewed on oscilloscope.

(7) Turn off both equipments and disconnect output of signal generator from oscilloscope.

(8) Connect signal generator to equipment to be tested in accordance with the authorized testing instructions issued for the equipment under test and proceed as directed.

b. Externally Synchronized Operation,

(1) Connect desired synchronizing signal to SYNC IN connector of signal generator (fig. 3-2).

(2) Set RANGE selector to range which includes frequency of synchronizing input signal.

(3) Adjust FREQUENCY dial to a value slightly below frequency of synchronizing input signal.

(4) Proceed in the same manner as outlined in a (3) through (8) above.

c. Impedance Matching.

(1) When applying a signal into a high impedance load, such as the grid circuit of an amplifier, the output may be taken from either the 75-ohm or the 600-ohm output connector without noticeable effect on the waveform.

(2) When operating from the 75-ohm output

into a 75-ohm load, a 75-ohm connecting cable, such as RG-59/U, should be used.

(3) When the signal generator is operating into a load impedance that is lower than 75 ohms, the impedance matching network similar to that shown in A, figure 3-3, should be used. For example, with a load impedance of 50 ohms (Z_2) and a signal generator output impedance of 75 ohms (Z_1), the values of R_1 and R_2 of A, figure 3-3, are determined in the following manner:

$$\begin{aligned}
 R_1 &= Z_1 \sqrt{1 - \frac{Z_2}{Z_1}} \\
 &= 75 \sqrt{1 - \frac{50}{75}} \\
 &= 75 \sqrt{.33} \\
 &= 75 \times .58 \text{ (approx)} \\
 &= 43 \text{ ohms (approx)} \\
 R_2 &= \frac{Z_2}{\sqrt{1 - \frac{Z_2}{Z_1}}} \\
 &= \frac{50}{.58} \\
 &= 86 \text{ ohms}
 \end{aligned}$$

With these values for R_1 and R_2 , the signal generator works into a load of approximately 75 ohms and the load sees approximately 50 ohms.

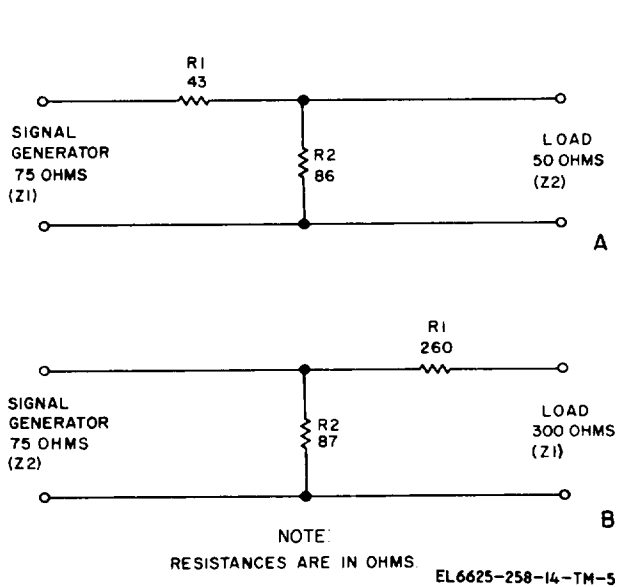

Figure 3-3. Impedance matching networks

(4) When the signal generator is operating into a load impedance that is higher than 75 ohms, the impedance matching network similar to that shown in B, figure 3-3 should be used. For example, with a load impedance of 300 ohms (Z1) and a signal generator output impedance of 75 ohms Z2), the values of R1 and R2 are determined in the following manner:

NOTE

The designation Z1 is always assigned to the higher impedance value when this method is used.

$$\begin{aligned}
 R1 &= Z1 \sqrt{1 - \frac{Z2}{Z1}} \\
 &= 300 \sqrt{1 - \frac{75}{300}} \\
 &= 300 \sqrt{1 - .25} \\
 &= 300 \sqrt{.75} \\
 &= 300 \times .866 \\
 &= 260 \text{ ohms (approx)} \\
 R2 &= \sqrt{\frac{Z2}{1 - \frac{Z2}{Z1}}} \\
 &= 1 \sqrt{\frac{75}{.75}} \\
 &= \frac{75}{.866} \\
 &= 87 \text{ ohms (approx)}
 \end{aligned}$$

With these values for R1 and R2, the signal generator works into a load of approximately 75 ohms and the load sees approximately 300 ohms.

3-6. Stopping Procedure

To stop the signal generator, set the power switch to off (down). Disconnect line cord from power source.

Section III. OPERATION UNDER UNUSUAL CONDITIONS

3-7. Operation in Arctic Climates

Subzero temperatures and climatic conditions associated with cold weather affect the efficient operation of electronic equipment. Instructions and precautions for operation under such adverse conditions follow.

- a. Handle equipment carefully.
- b. Keep equipment warm and dry. If signal generator is not kept in a heated inclosure, construct an insulated box for the equipment.
- c. Make certain the equipment is warmed up sufficiently before attempting to use it. This may take 10 to 15 minutes, depending on the temperature of the surrounding air.
- d. When equipment which has been exposed to the cold is brought into a warm room, it will start to sweat and will continue to do so until it reaches room temperature. When the signal generator has reached room temperature, dry it thoroughly.

3-8. Operation in Tropical Climates

When operated in tropical climates, electronic equipment may be installed in tents, huts, or, where necessary, underground dugouts. When equipment is installed below ground, and when it is set up in swamp areas, moisture conditions are more acute than normal in the tropics. Ventilation usually is very poor, and the high relative humidity causes condensation of moisture on the equipment whenever the temperature of the equipment becomes lower than the ambient air. To minimize this condition, place lighted electric bulbs under the equipment.

3-9. Operation in Desert Climates

The main problem with equipment operation in desert areas is the large amount of sand and dust that enters the moving parts of the equipment. Therefore, cleaning and servicing intervals shall be shortened according to local conditions.

CHAPTER 4

OPERATOR AND ORGANIZATIONAL MAINTENANCE INSTRUCTIONS

Section I. OPERATOR AND ORGANIZATIONAL TOOLS AND EQUIPMENT

4-1. Common Tools and Equipment

Tools and test equipment used by the operator and organizational repairman for the signal generator are listed in appendix C.

4-2. Special Tools and Equipment

No special tools are required for maintenance.

4.3. Lubrication Instructions.

Lubrication instructions are given in paragraph 4-9.

Section II. PREVENTIVE MAINTENANCE CHECKS AND SERVICES

4-4. General

Preventive maintenance is the systematic care, servicing, and inspection of equipment to prevent the occurrence of trouble, to reduce downtime, and to assure that the equipment is serviceable. The necessary preventive maintenance checks and services to be performed are listed and described in tables 4-1, 4-2, and 4-3. Item numbers indicate the sequence of minimum inspection requirements. Defects discovered during operation of the unit will be noted for future correction, to be made as soon as operation has ceased. Operation shall be stopped immediately if a deficiency is noted which would damage the equipment. Record all deficiencies together with corrective action taken as prescribed in TM 38.750.

4-5. Scope of Operator's Maintenance

The maintenance duties assigned to the operator of the signal generator are listed below.

a. Daily preventive maintenance checks and services (table 4-1).

b. Weekly preventive maintenance checks and services (table 4-1).

c. Cleaning (para 4-8).

d. Troubleshooting (table 4-4, step a).

e. Repairs.

(1) Replacement of power pilot lamp (para 4-13 a).

(2) Replacement of fuse (para 4.13 b).

4-6. Systematic Care

The procedures given in tables 4-1 through 4-3,

along with paragraphs 4-8 and 4-9, cover routine systematic care and cleaning essential to proper upkeep of this equipment when it is used separately. When this equipment is used as part of a set or system, follow the procedures established in the set or system manual.

4-7. Preventive Maintenance Checks and Services Periods

Preventive maintenance checks and services of the signal generator are required daily, weekly, monthly, and quarterly.

a. Table 4-1 specifies checks and services that must be accomplished daily and under the special conditions listed below:

(1) At least once each week if the equipment is maintained in standby condition.

(2) When the equipment is initially installed.

(3) When the equipment is reinstalled after removal for any reason.

b. Tables 4-1 through 4-3 specify additional checks and services that must be performed on a weekly, monthly, and quarterly basis, respectively.

c. To assist in maintaining combat serviceability, the tables indicate what to check, how to check, and what normal conditions are. References included are to tables, illustrations, paragraphs, or manuals that contain detailed repair or replacement procedures. If the defect cannot be remedied by performing the corrective actions indicated, higher maintenance category repair is required.

Table 4-1. Operator/Crew Preventive Maintenance Checks and Services

D – Daily
Time Required: 1.3

W – Weekly
Time Required: 0.2

Interval and sequence No.		ITEM TO BE INSPECTED PROCEDURE	Work time (M/H)
D	W		
1		EXPOSED ITEMS Clean exposed surfaces of case and control panel (para 4-8).	0.1
2		CONTROLS Check that mechanical action of each knob, switch, and control is smooth and free of binding and no excessive looseness is apparent.	0.1
3		PRELIMINARY a. Set Power ON switch to off (down). b. Set OUTPUT AMPLITUDE controls at 0- and 75-ohm ATTEN switch to 60 dB. c. Connect power cord to appropriate power source receptacle. d. Connect oscilloscope to 600-ohm output terminals.	0.6
4		Power ON switch Set power ON switch to ON. Note that power pilot lamp lights and a square wave appears on oscilloscope (table 4-4).	0.1
5		OUTPUT AMPLITUDE—600-ohm control Turn OUTPUT AMPLITUDE—600-ohm control from full counterclockwise (0) to fully clockwise (10 or 60). Observe that output signal increases in amplitude (para 4-11).	
6		OUTPUT AMPLITUDE—75-ohm control Connect oscilloscope to 75-ohm output connector. Turn OUTPUT AMPLITUDE – 75-ohm control from fully counterclockwise (0) to fully clockwise (10 or 7). Observe that output signal increases in amplitude (para 4-11).	
7		75-OHM ATTEN switch Turn 75-ohm ATTEN switch to each position. Observe that output signal amplitude changes in steps of 10 to 1. (Higher maintenance category repair is required if operation is abnormal.)	
8		SYMMETRY control Observe output signal end adjust SYMMETRY control. Symmetrical waveshape should be obtained. (Higher maintenance category repair is required if operation is abnormal.)	0.1
9		RANGE switch and FREQUENCY control Turn RANGE switch through all positions and vary FREQUENCY dial through each range. On oscilloscope, frequency change should be apparent without major change in amplitude. (Higher maintenance category repair is required if operation is abnormal.)	0.1
10		SYNC IN connector Connect an external synchronizing signal (minimum 5 volts peak) to the SYNC IN connector. Adjust signal generator to frequency slightly below that of the synchronizing signal. Observe that the output frequency of the signal generator is the same as the external synchronizing generator. (Higher maintenance category repair is required if operation is abnormal.)	0.2
1		POWER CORD Inspect cord for chafed, cracked, or frayed insulation. Replace cord that is stripped or worn excessively.	0.1
2		HANDLES AND LATCHES Inspect handles and latches for looseness. Replace or tighten as necessary.	0.1
3		METAL SURFACES Inspect exposed metal surfaces for rust and corrosion. Clean and touch up paint as required (para 4-10).	

Table 4-2. Organizational Preventive Maintenance Checks and Services

M – Monthly
Total man-hours required: 1.1

Sequence number	ITEM TO BE INSPECTED PROCEDURE	Work time (M/H)
1	PLUCKOUT ITEMS Inspect seating of pluckout items. Make certain that tube clamps grip tube bases tightly. Do not remove, rock, or twist to inspect; use only direct pressure to insure item is fully seated (table 4-4).	0.4
2	CONNECTORS Inspect connectors for snug fit and good contact.	0.1
3	TRANSFORMER Inspect terminals on power transformer. No dirt or corrosion should be evident (pars 4-8).	0.1
4	TERMINAL BLOCKS AND COMPONENT BOARDS Inspect for loose connections and cracked or broken insulation.	0.1
5	FAN MOTOR Lubricate fan motor (para 4-9).	0.4
4-2		

Table 4-3. Organizational Preventive Maintenance Checks and Services

Q-Quarterly
 Total man-hours required: 0.5

Sequence number	ITEM TO BE INSPECTED PROCEDURE	work time (M/H)
1	PUBLICATIONS See that all publications are complete, serviceable, and current (DA Pam 310-4).	0.5
2	MODIFICATIONS Check DA Pam 310-7 to determine if new applicable MWO'S have been published. All urgent MWO'S must be applied immediately. All normal MWO'S must be scheduled (TM 38-750 and DA Pam 310-7).	
3	SPARE PARTS Check all spare parts (operator and organizational) for general condition and method of storage. No overstock should be evident and all shortages must be on valid requisitions.	

4-8. Cleaning

Inspect the exterior surfaces of the signal generator; exterior surfaces should be clean, free of dust, dirt, grease, and fungus.

a. Remove dust and loose dirt with a clean, soft cloth.

WARNING

The fumes of trichloroethane are toxic. Provide thorough ventilation whenever used. **DO NOT USE NEAR AN OPEN FLAME.** Trichloroethane is not flammable, but exposure of the fumes to an open flame or hot metal forms highly toxic phosgene gas.

b. Remove grease, fungus, and ground-in dirt from the case; use a cloth dampened (not wet) with trichloroethane (NSN 6810-00-292-9625).

c. Remove dust or dirt from connectors with a brush.

d. Clean the front panel and control knobs; use a soft, clean cloth. If dirt is difficult to remove, dampen the cloth with water; use mild soap if necessary.

4-9. Lubrication

The ventilating and cooling fan motor (fig. 4-1) has oilholes in the bearing housings at each end of the shaft. One or two drops of light oil (LO), applied monthly to each bearing, will provide suitable lubrication under normal operating conditions.

NOTE

The fan motor in the A model requires no lubrication.

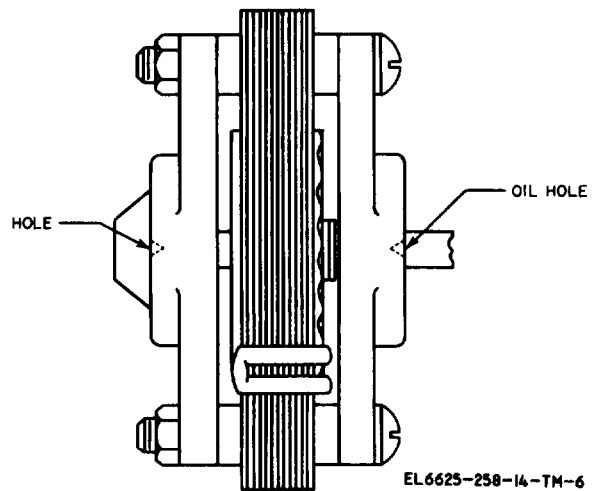

Figure 4-1. Fan motor oilhole location.

4-10. Touchup Painting

Remove rust and corrosion from metal surfaces by lightly sanding them with fine sandpaper. Brush two thin coats of paint on the bare metal to

protect it from further corrosion. Refer to applicable cleaning and refinishing practices specified in TB 746-10.

Section III. TROUBLESHOOTING

4-11. General Troubleshooting Information

Troubleshooting this equipment is based upon the operational check contained in the daily preventive maintenance checks and services table. To troubleshoot the equipment, perform all functions in table 4-1 and proceed through the items until an abnormal condition or result is observed. When an abnormal condition or result is observed, note the trouble and sequence number and go directly to the corresponding

trouble in the troubleshooting table 4-4, Perform the checks and corrective actions indicated in the troubleshooting table. If the corrective measures indicated do not result in correction of the trouble, higher maintenance category repair is required. Paragraphs 4-12 and 4-13 (referenced in table 4-4) contain additional information and step-by-step instructions for performing equipment tests and repairs to be used during the troubleshooting procedures.

Table 4-4. Organizational Troubleshooting

<i>Malfunction</i>	<i>Probable cause</i>	<i>Corrective action</i>
a. Power pilot lamp does not light.	a. Defective lamp DS1 or blown fuse F1.	a. Replace lamp DS1 or fuse F1 (para 4-13),
b. No output signal (power pilot lamp lights).	b. Defective tube	b. Check tubes (para 4-12).
c. With amplitude control fully clockwise, output signal amplitude low (less than 30 volts).	c. Defective tube	c. Check tubes (para 4-12).

4-12. Tube Testing Techniques

When a malfunction occurs, try to isolate the trouble to an assembly or stage before removing any tubes. If tubes failure is suspected, use the applicable procedure below to check the tubes. To reach the tubes, remove screws around front panel and slide panel-chassis assembly from case. Figures 4-2 and 4-3 show tube locations.

removing it from a socket; pull the tube straight out with a tube puller. Failure to comply may result in damage to the tube or socket.

a. Use of Tube Tester. Remove and test one tube at a time. Discard a tube only if its defect is obvious or if the tube tester shows it to be defective. Do not discard a tube that tests at or near its minimum test limit on the tube tester.

CAUTION

Do not rock or rotate a tube when

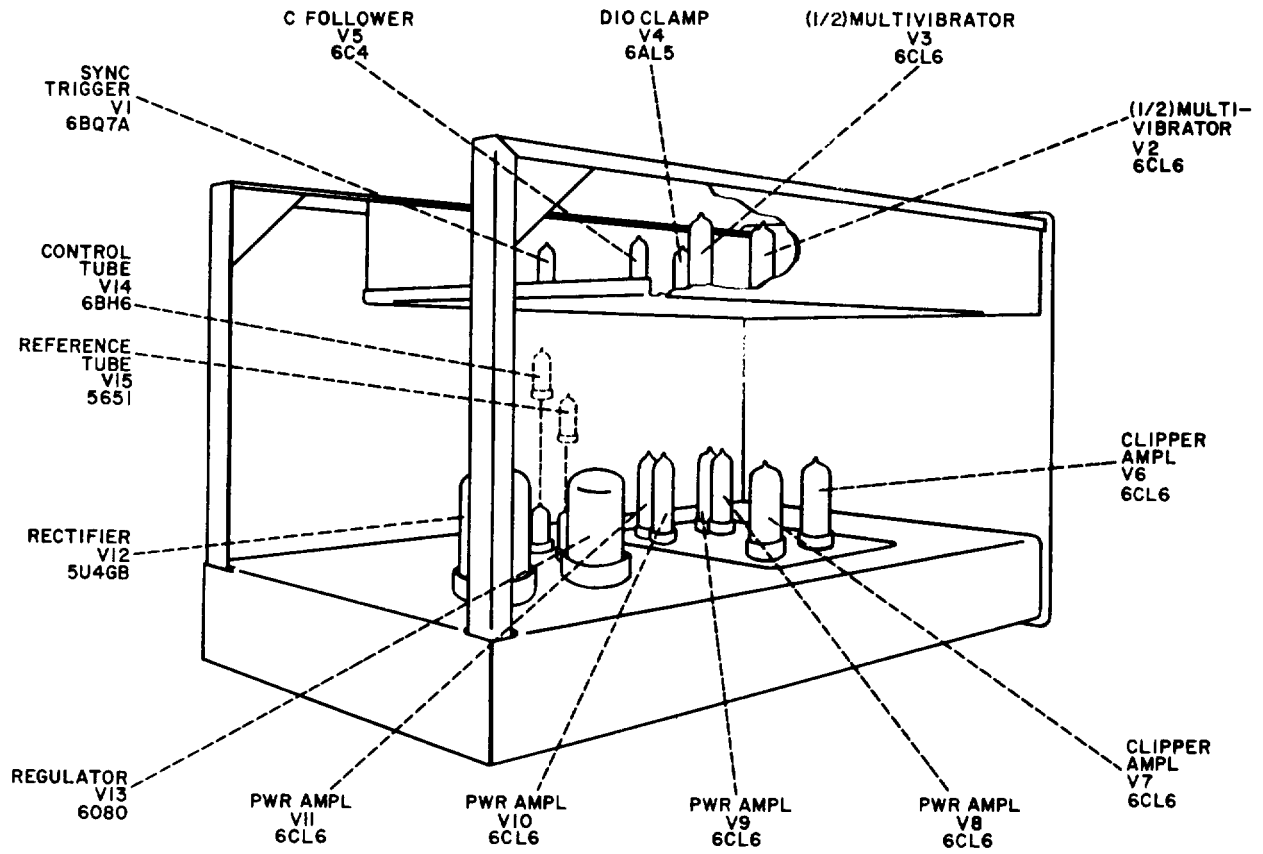

EL6625-258-14-TM-7

Figure 4-2. Signal Generator, SG-299/U, SG-299B/U, SG-299C/U, SG-299D/U, and SG-299E/U tube locations.

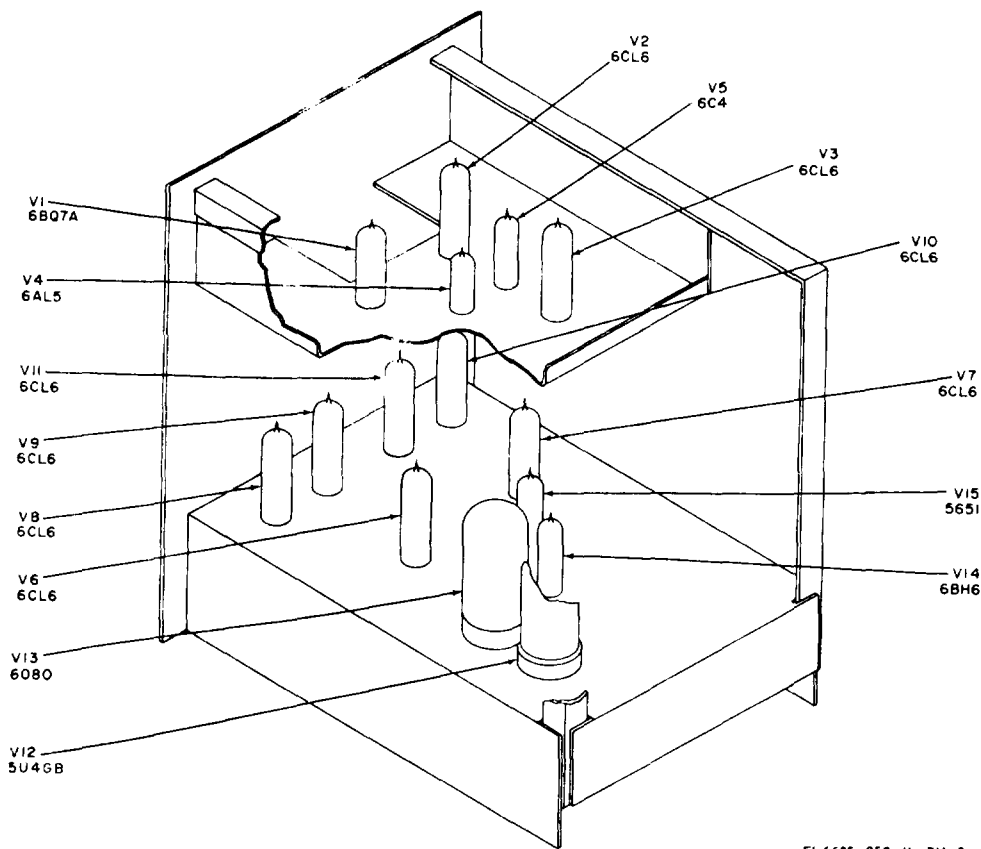

EL6625-258-14-TM-8

Figure 4-3. Signal Generator, SG-299A/U, tube locations.

b. *Tube Substitution Method.* Replace a suspected tube with a new tube. If the equipment still does not work, remove the new tube and replace the original tube. Repeat this procedure with each suspected tube until the defective tube is located.

Adjustments must be made in the signal generator following replacement of certain tubes. The following table (4-5) lists all of the tubes in the equipment with reference to the required adjustment and the applicable instruction paragraph.

c. *Adjustment Following Tube Replace-*

Table 4-5. Adjustments Following Tube Replacements

Tube	Type	Function	Adjustment
U1	6BQ7	Sync trigger	Adjust sync sensitivity (para 6-14).
U2	6CL6	½ multivibrator	Recalibrate FREQUENCY dial (para 6-13).
U3	6CL6	½ multivibrator	Recalibrate FREQUENCY dial (para 6-13).
U4	6AL5	Diode clamp	Recalibrate FREQUENCY dial (para 6-13).
U5	6C4	Clamp control cathode follower	Recalibrate FREQUENCY dial (para 6-13).
U6	6CL6	75-ohm output clipper amplifier	None
U7	6CL6	600-ohm output clipper amplifier	None
U8	6CL6	75-ohm output tube	None
U9	6CL6	75-ohm output tube	None
U10	6CL6	600-ohm output tube	None
U11	6CL6	600-ohm output tube	None
U12	5U4GB	Full-wave rectifier	Adjust -200 V (para 6-12).
U13	6080	Series regulator	Adjust -200 V (para 6-12).
U14	6BH6	Control tube	Adjust -200 V (para 6-12).
U15	5651	Reference tube	Adjust -200 V (para 6-12).

4-13. Repairs*a. Replacement of Pilot Lamp.*

- (1) Remove the two screws, behind the case, that hold chassis to case.
- (2) On the edge of the front panel, remove screws (4 or 10, depending on model) that secure panel to case. Remove from case.
- (3) Press in and turn pilot lamp counterclockwise to unlock it.
- (4) Remove defective lamp and replace it with new one. Push and twist lamp clockwise to lock in.

b. Replacement of Fuse.

- (1) At rear of signal generator turn fuseholder cap counterclockwise until free from fuseholder.
- (2) Remove defective fuse and replace with good fuse having same voltage and current ratings.
- (3) Replace fuseholder cap in fuseholder; push in and turn cap clockwise to secure.

CHAPTER 5

FUNCTIONING OF EQUIPMENT

5.1. General

The signal generator is a wide-range, squarewave generator used with a fast rise time oscilloscope for testing video amplifier response characteristics. It consists of a free-running, plate-coupled multi-vibrator which produces a squarewave output signal. The frequency of the output signal is adjustable from 1 Hz to 1 MHz. The squarewave output of the multivibrator is fed to a push-pull clipper amplifier stage which, in turn, feeds a power stage consisting of four tubes connected in push-pull parallel. The power amplifier stage is terminated in two separate output systems. The 75-ohm output is adjusted by a variable amplitude control and a 0- to 60-dB four-step (increments of 20-dB) constant impedance attenuator network. The 600-ohm output is

adjusted by a two-section balanced, amplitude control. The two outputs may be used separately or simultaneously. A trigger circuit coupled to the multivibrator permits synchronization of the signal generator with an external signal source. To maintain stable operation of the equipment, plate voltage for the various circuits is supplied by a regulated power supply designated to maintain a constant dc output voltage within 1 percent over line voltage variations from 105 volts to 125 volts ac.

5-2. Block Diagram Description

The block diagram of the signal generator (fig. 5-1) is described in a through g below. For complete circuit details, refer to the schematic diagrams at the back of the manual.

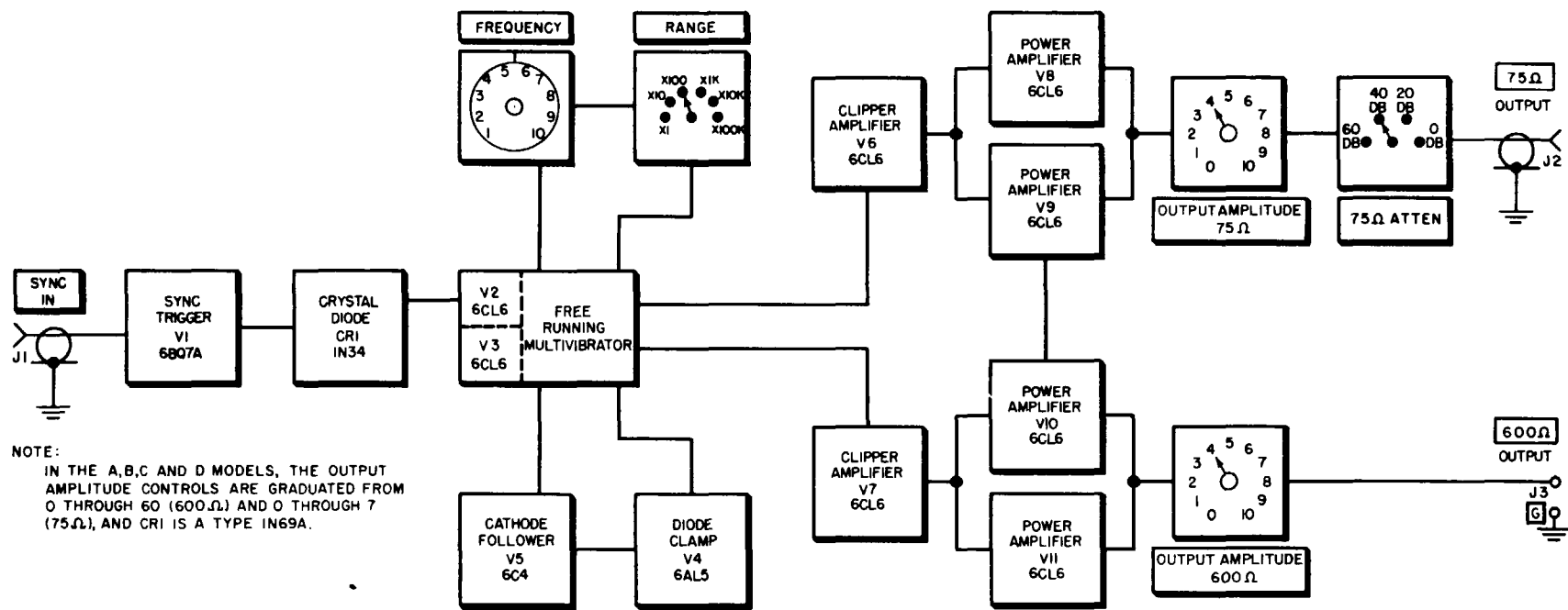

NOTE:
 IN THE A,B,C AND D MODELS, THE OUTPUT AMPLITUDE CONTROLS ARE GRADUATED FROM 0 THROUGH 60 (600Ω) AND 0 THROUGH 7 (75Ω), AND C1 IS A TYPE IN69A.

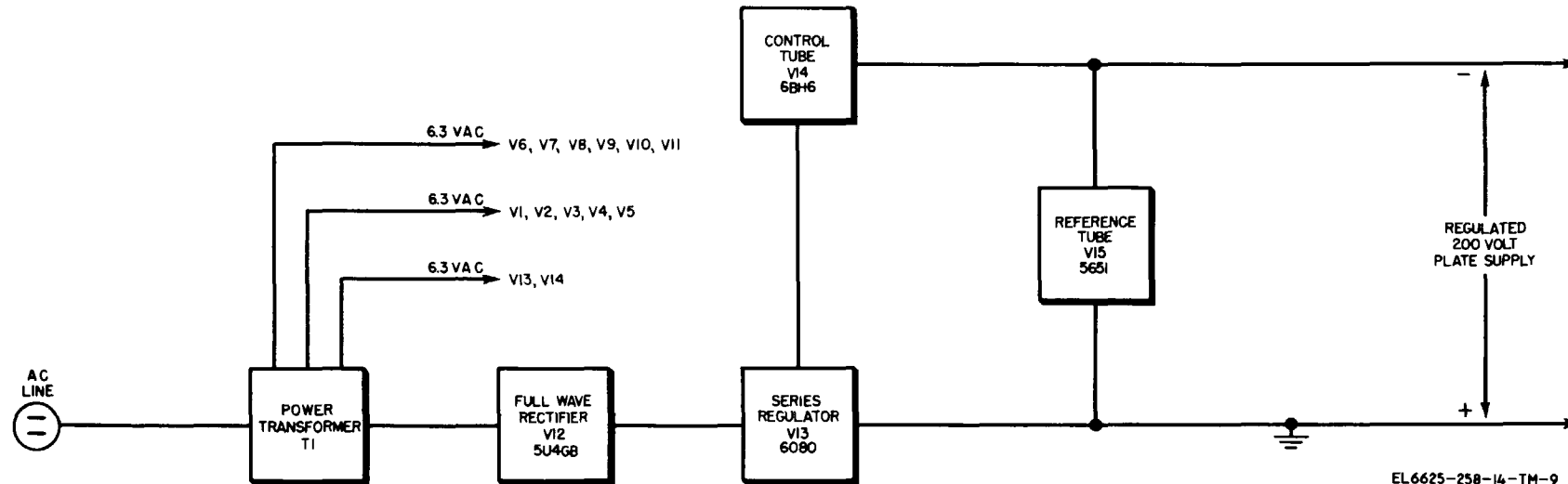

EL 6625-258-14-TM-9

Figure 5-1. Signal Generator SG-299(*) /U, block diagram.

a. *Sync Trigger.* The sync trigger VI accepts an external synchronizing signal (positive pulse or sine wave) through SYNC IN jack J1 and converts it into a spike-shaped output signal. This output is coupled through crystal diode CR1 to control the multivibrator frequency.

b. *Multivibrator.* Tubes V2 and V3 are wired to operate a plate-coupled multivibrator. Clamping diodes (dual sections of V4) are used with cathode follower V5 to stabilize the output of the multivibrator. The multivibrator is in a free-running mode when no external synchronizing signal is applied through the sync trigger circuit. The RANGE switch selects the proper RC time constant to be inserted in the circuit and, with the FREQUENCY control, determines the operating frequency. The push-pull output from the multivibrator is coupled to clipper amplifiers V6 and V7.

c. *Clipper Amplifiers.* The clipper amplifiers shape the signals from the multivibrator and provide the squarewave signal voltage to the power amplifiers.

d. *Power Amplifiers.* Four type 6CL6 tubes, V8, V9, V10, and V11, are connected in a push-pull parallel arrangement in the power amplifier. The signals from the clipper amplifiers are coupled to the power amplifier tubes, which amplify and apply the squarewave output to the OUTPUT AMPLITUDE 75 Ω and 600 Ω controls.

e. *75-Ohm Output.* The output of power amplifiers V8 and V9 is coupled through the

OUTPUT AMPLITUDE-75 Ω output connector J2.

f. *600-Ohm Output.* The output of power amplifiers V 10 and V11 is coupled through the OUTPUT AMPLITUDE-600 Ω control to 600 Ω output connector J3.

g. *Power Supply.* An ac line voltage is applied across the primary of power transformer T1. The secondary windings of T1 supply all filament and heater voltages and the necessary high voltage for operation of full-wave rectifier V12. Series regulator V 13, control tube V 14, and reference tube V 15 form a feedback control system to minimize any shift of the — 200-volt dc plate supply .

5-3. Multivibrator

(fig. 5-2)

a. The multivibrator in the signal generator uses two 6CL6 tubes connected in an RC plate-coupled multivibrator circuit. Capacitors CX1 and CX2 provide coupling between the two sections of the multivibrator and, in conjunction with grid resistors RX1, RX2, and RX3, comprise a timing network which determines the range of multivibrator frequency. The values of these components are changed for each frequency range as selected by the RANGE switch (para 5-4 and fig. 5-3). FREQUENCY control R9 provides a variable grid-return voltage which results in a frequency adjustment on each range in a ratio of 10 to 1.

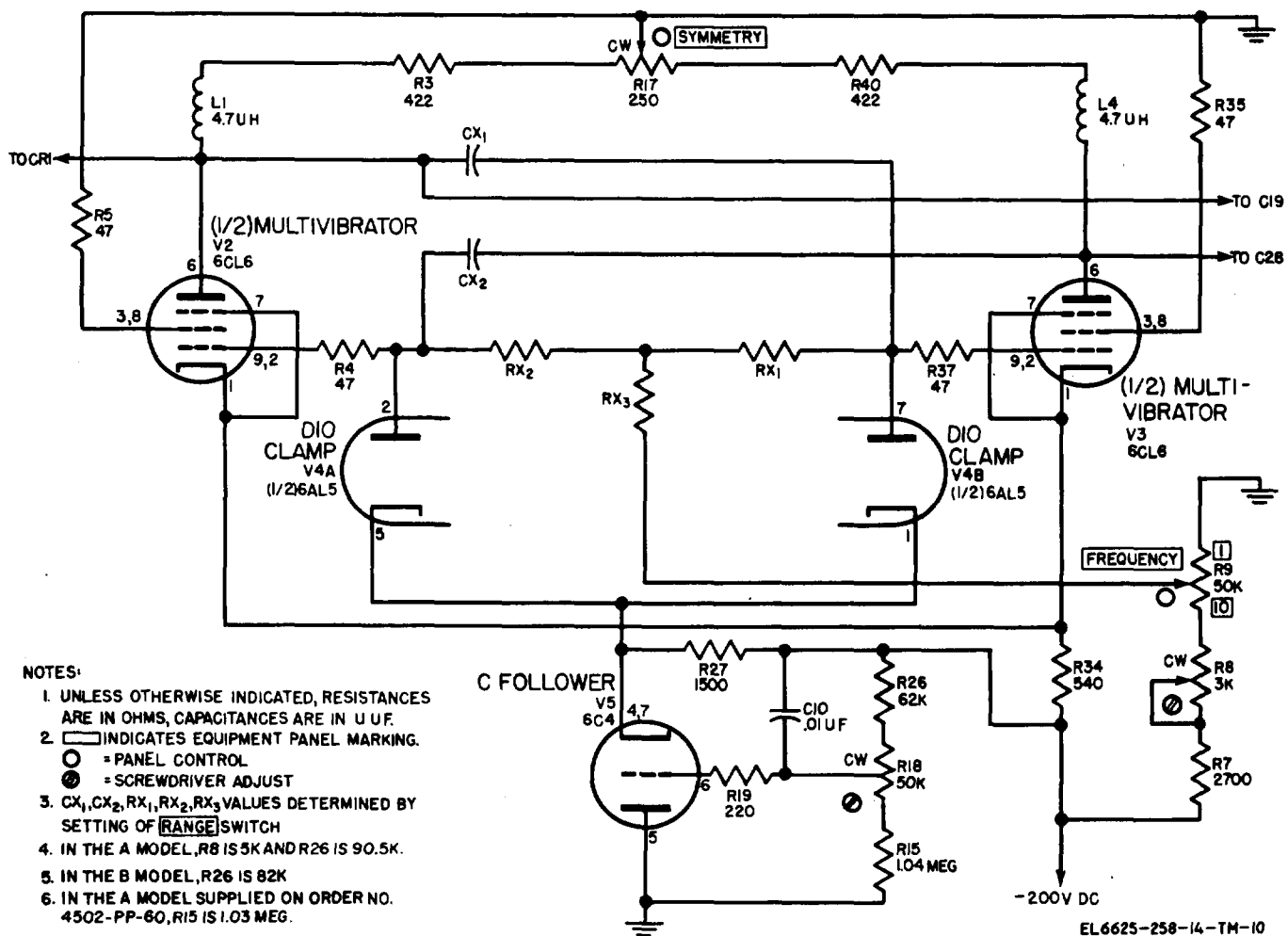

Figure 5-2. Multivibrator circuit, simplified schematic diagram.

b. A negative type power supply is used throughout this signal generator. Thus, the plates of all amplifier tubes are returned to ground. Tubes V2 and V3 alternately conduct and cutoff. With V2 not conducting, CX1 charges to the full value of the plate supply voltage. The coupling of CX1 to the grid of V3 through R37 causes the grid of V3 to become more positive, thereby increasing plate current through V3. The plate voltage of V3 decreases because of the voltage drop across its plate load, R40 and L4. This change in voltage is coupled through CX2 and R4 to the grid of V2, driving V2 beyond cutoff. When the plate current of V3 stabilizes and there is no further change in plate voltage, the bias on V2 decreases to above cutoff through resistors RX2, RX3, and R9, thereby allowing V2 to conduct. When V2 conducts, its plate voltage decreases because of the drop across its plate load, R3 and L1. This drop is coupled through CX1 and R37 to the grid of V3, driving V3 into

cutoff. Resistors RX 1, RX3, and R9 form the grid leak resistance for V3, enabling it to return to a conducting state to complete one cycle of operation.

c. FREQUENCY control R9, with calibration resistor R8 and fixed resistor R7, serves as a voltage divider across the - 200-volt supply. Varying FREQUENCY control R9 changes the bias on the multivibrator tubes, and, in turn, the frequency of operation. Resistor R34 serves as the cathode return for V2 and V3.

d. A diode clamp circuit consisting of V4 and V5 limits the peak voltage applied to the grids of V2 and V3 and improves the squarewave output from the multivibrator. The cathodes of the diode clamps are returned through R27 (cathode resistor for V5) to the - 200-volt supply. These clamp tubes remain cutoff until the grid voltage applied to the multivibrator exceeds the negative voltage at the cathodes of the diode clamps. This voltage causes the plates of the diode clamps to

become positive and the diode clamps conduct, thus limiting the peak voltage applied to the grid of V2 and V3.

e. Operating bias of V5 is determined by the drop across cathode resistor R27. The current through cathode follower V5 can be adjusted by variable resistor R18 which, in series with resistors R26 and R15, serves as a voltage divider across the - 200-volt supply. C10 and R19 are included in the circuit to reduce the effects of parasitic.

f. The output of the multivibrator is a squarewave form. SYMMETRY control R17 balances the periods of conduction from the two halves of the circuit. The output of V2 and V3 is applied through capacitors C19 and C28 to the clipper amplifiers. Resistors R5 and R35 are parasitic resistors inserted in the screen grids of V2 and V3 for more stable operation.

5-4. RANGE Switch

(fig. 5-3)

The function of RANGE switch S1 is to insert different RC time constants into the

multivibrator circuit for the various frequency ranges. It is a six-position wafer-type switch with 600 indexing between positions.

a. On the X1 range (shown), capacitor C12 is connected between the plate of V3 and the grid of V2. Resistor R28 is the grid resistor for V2 on this range. Capacitor C1 is connected between the plate of V2 and the grid of V3; resistor R10 is the grid resistor for V2 on this range. The junction of resistors R28 and R10 is connected through X1 calibration control R20 to FREQUENCY control R9.

b. On the X10 range, capacitors C13 and C2 replace capacitors C12 and C1, and resistors R29 and R11 replace resistors R28 and R10. The junction of R29 and R11 is connected through X10 calibration control R21 to FREQUENCY control R9,

c. On the X 100 range, capacitors C14 and C3 replace capacitors C 13 and C2. The junction of resistors R29 and R11 is connected through resistor R22 to FREQUENCY control R9.

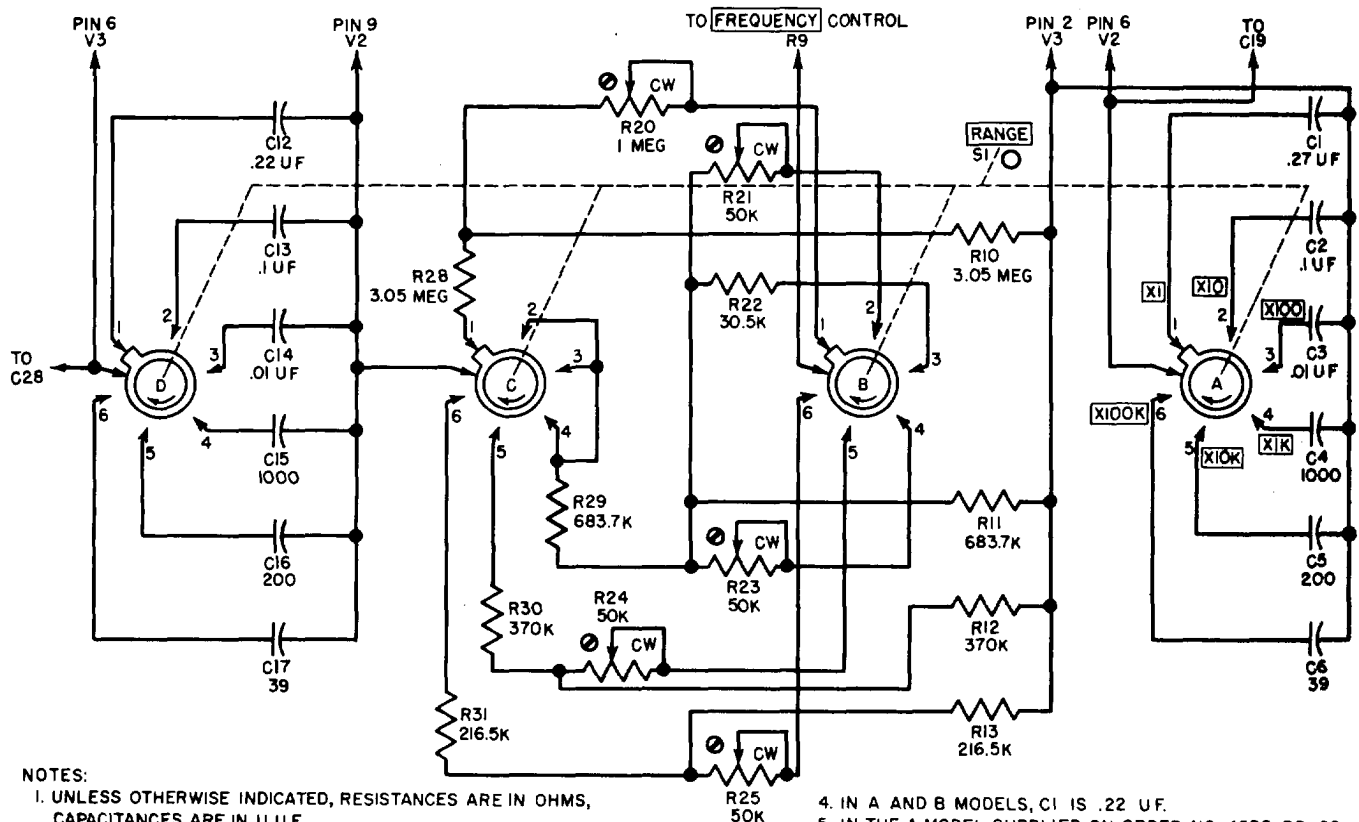

- NOTES:
1. UNLESS OTHERWISE INDICATED, RESISTANCES ARE IN OHMS, CAPACITANCES ARE IN UUF.
 2. □ INDICATES EQUIPMENT PANEL MARKING.
○ = PANEL CONTROL ⊕ = SCREWDRIVER ADJUST
 3. SWITCH SECTIONS ARE SHOWN IN COUNTERCLOCKWISE POSITION AS VIEWED FROM KNOB END. WAFER SECTION "A" CLOSEST TO KNOB.

4. IN A AND B MODELS, C1 IS .22 U.F.
5. IN THE A MODEL SUPPLIED ON ORDER NO. 4502-PP-60, R11 AND R29 ARE 684K AND R13 AND R31 ARE 216K.

Figure 5.3 RANGE switch schematic diagram.

d. On the X1K range, capacitors C15 and C4 replace capacitors C14 and C3. The junction of resistors R29 and R11 is connected through X1K calibration control R23 to FREQUENCY control R9.

e. On the X10K range, capacitors C16 and C5 replace capacitors C15 and C4, and resistors R30 and R12 replace resistors R29 and R11. The junction of resistors R30 and R12 is connected through X10K calibration control R24 to FREQUENCY control R9.

f. On the X100K range, capacitors C17 and C6 replace capacitors C16 and C5, and resistors R31 and R13 replace resistors R30 and R12. The junction of R31 and R13 is connected through X100K calibration control R25 to FREQUENCY control R9.

5-5. Sync Trigger
(fig. 5-4)

a. When synchronization is required, an external sync signal is injected into SYNC IN jack J1. This external signal is applied across resistor R32 through capacitor C8, and coupled to the grid of V1B through parasitic suppressor R16. Resistors R6 and R38 comprise a voltage dividing network that biases the grid of V1B beyond cutoff. Application of a positive-going pulse of at least a 3-volt peak drives V1B into conduction. The increased voltage drop across resistor R1 causes the plate voltage of V1B to drop. The inductive action of L2 produces a sharp leading edge on the waveform at the plate of V1B.

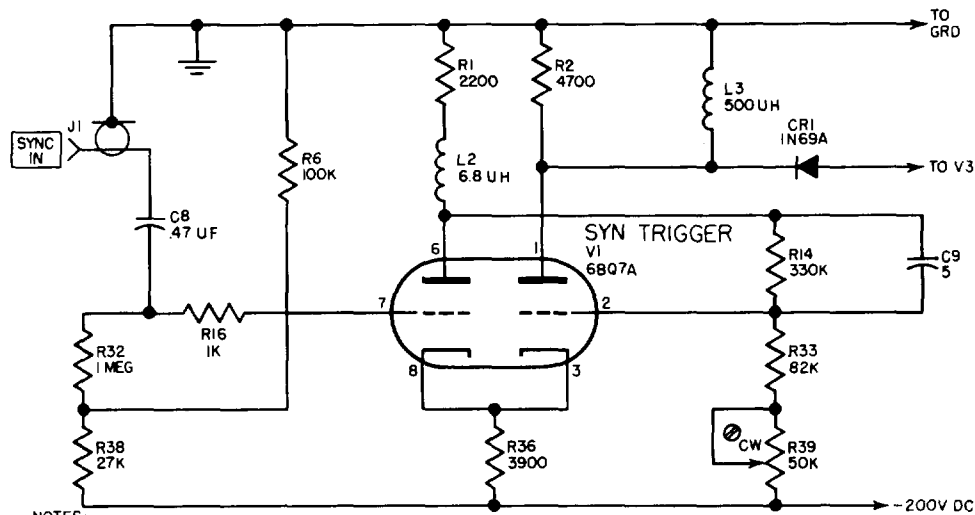

- NOTES:
1. UNLESS OTHERWISE INDICATED, RESISTANCES ARE IN OHMS, CAPACITANCES ARE IN UUF.
 2. □ INDICATES EQUIPMENT PANEL MARKING ⊕ = SCREWDRIVER ADJUST.
 3. IN THE UNLETTERED MODEL, CRI IS A TYPE IN34.

EL6625-258-14-TM-12

Figure 5-4. Sync trigger circuit simplified schematic diagram.

b. Section V1A is normally conducting. When the plate voltage of V1B goes negative, V1A is driven into cutoff due to the coupling through capacitor C9 and resistor R14. Inductance L3 in the plate circuit of V1B offers zero impedance when this section of the tube is conducting, thereby effectively shorting out resistor R2. However, when V1A is cut off by application of a sharp pulse to the grid, L3 presents a very high impedance to the pulse and R2 becomes the effective plate load. When section V1B reaches a steady state of cutoff, during the pulse period, L3 again presents zero impedance until the tube is driven into conduction by the trailing edge of the pulse. Inductor L3 again presents a high impedance and R2 again becomes the effective load. Thus the output of V1A is differentiated, thereby producing a series of alternate spikes.

c. The negative spikes produced by V1 are coupled through crystal rectifier diode CR1 to the plate of V2, thereby providing synchronization for the multivibrator.

d. When using external synchronization, the negative spike from the sync trigger circuit, coupled to the grid of V3 (fig. 5-2) through CR1, cuts off V3. To obtain the proper synchronization in the multivibrator, the negative cutoff pulse from the trigger must reach the grid of V3 before the tube reaches cutoff as a result of normal free running operation. To accomplish this, the multivibrator must be adjusted to a frequency slightly lower than that of the incoming synchronizing signals.

e. Variable resistor R39, together with R33, controls the sensitivity of the sync trigger circuit. It is adjusted so that the system will trigger on a minimum sync input signal of 3-volts peak. In practice, it is recommended that 5-volt peak sine wave or positive pulse signal be used.

f. Resistor R36 serves as a common cathode bias resistor to limit current through both sections of V1.

5-6. Clipper Amplifier

(fig. 5-5)

a. The output of multivibrator tubes V2 and V3 is coupled through capacitors C19 and C28 to provide a push-pull driving signal for the two 6CL6 clipper amplifier tubes V6 and V7. This push-pull signal from the multivibrator drives clipper amplifier tubes V6 and V7 alternately into cutoff and into saturation, thereby producing amplified, square-topped output signals at the plates of V6 and V7.

b. The input signals are applied across grid resistors R54 and R70 and connected through parasitic suppressor resistors R52 and R73 to the control grids of V6 and V7, respectively. Resistors R41, R45, and R60 form a voltage divider across the - 200-volt dc supply to provide a fixed bias for the grids of V6 and V7. (In the A model, resistor R45 is omitted and the value of R41 is increased to 150K.) Resistor R61 serves as a common cathode. Resistors R46 and R78 in the screen circuits prevent parasitic.

c. The plate load of V6 consists of two resistors, R42 and R43, in parallel with a frequency compensating network made up of R47, C18, L5, R55, R62, and C23. A similar circuit made up of resistors R81 and R82 in parallel with the frequency compensating network R79, C30, L6, R71, R67, and C24 serves as the plate load for V7.

d. At low frequencies, R42, R43, R81, and R82 serve as the plate load for V6 and V7. However, as the frequency increases, the impedance of the compensating networks decreases and the networks function increasingly as a part of the effective plate loads for V6 and V7. This action of the compensating networks permits handling a wide band of frequencies by the clipper amplifier while maintaining the desired frequency response characteristics. The overall frequency response is further maintained by dc coupling to the power amplifier stage.

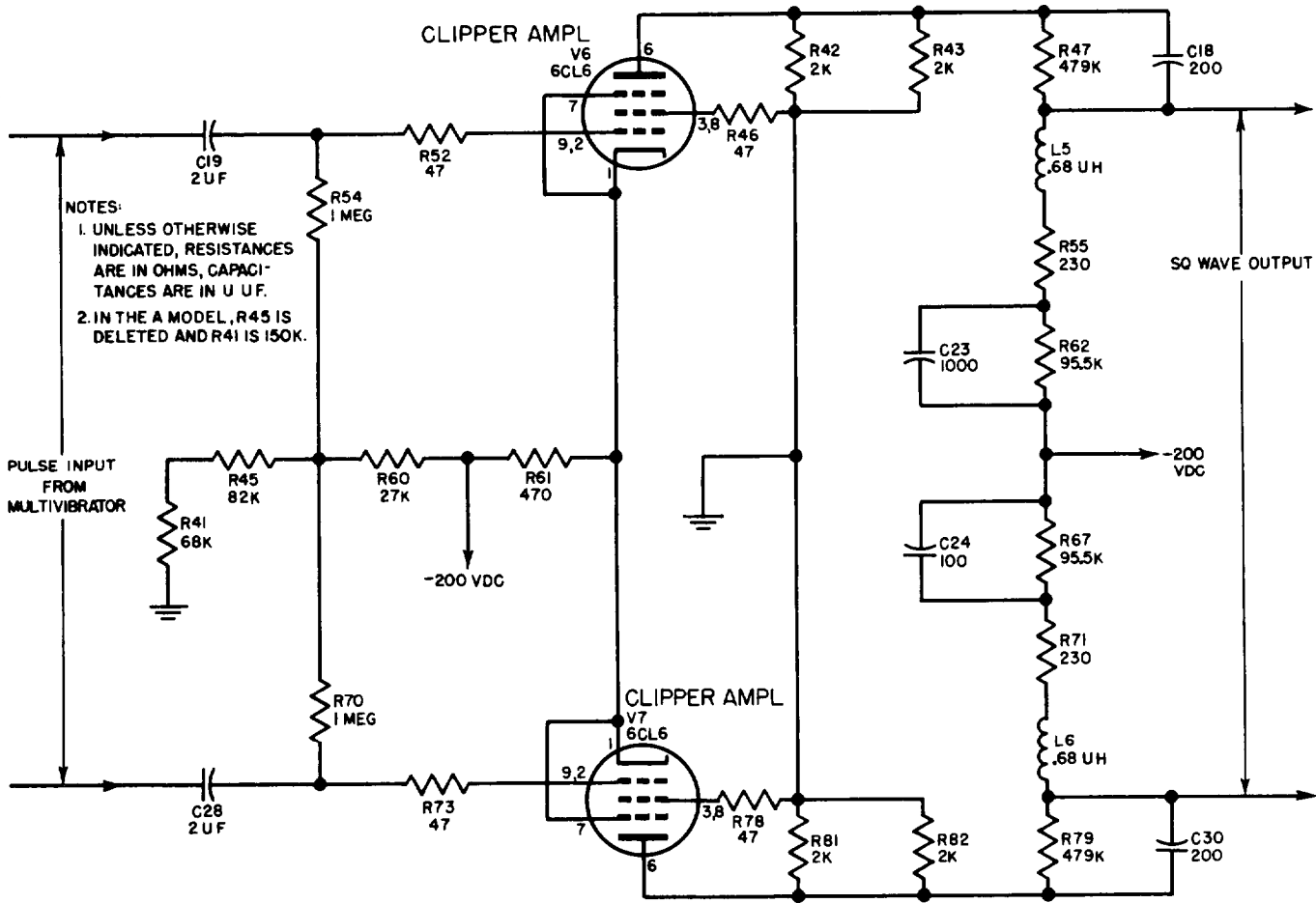

Figure 5-5. Clipper amplifier circuit, simplified schematic diagram.

5-7. Power Amplifier and 75 Ω ATTEN Switch

a. Power Amplifier (Fig. 5-6).

(1) The power amplifier consists of four type 6CL6 pentodes connected in push-pull parallel. The outputs from the clipper amplifier drivers, V6 and V7 are 180° out-of-phase with each other; therefore, one-half of the power amplifier is conducting while the other half is cutoff.

(2) Outputs from the clipper amplifier tubes are directly coupled from the plate load networks of V6 and V7 through parasitic suppressor resistors R48, R50, R76 and R80 to the grids of power amplifiers V8, V9, V10, and V11.

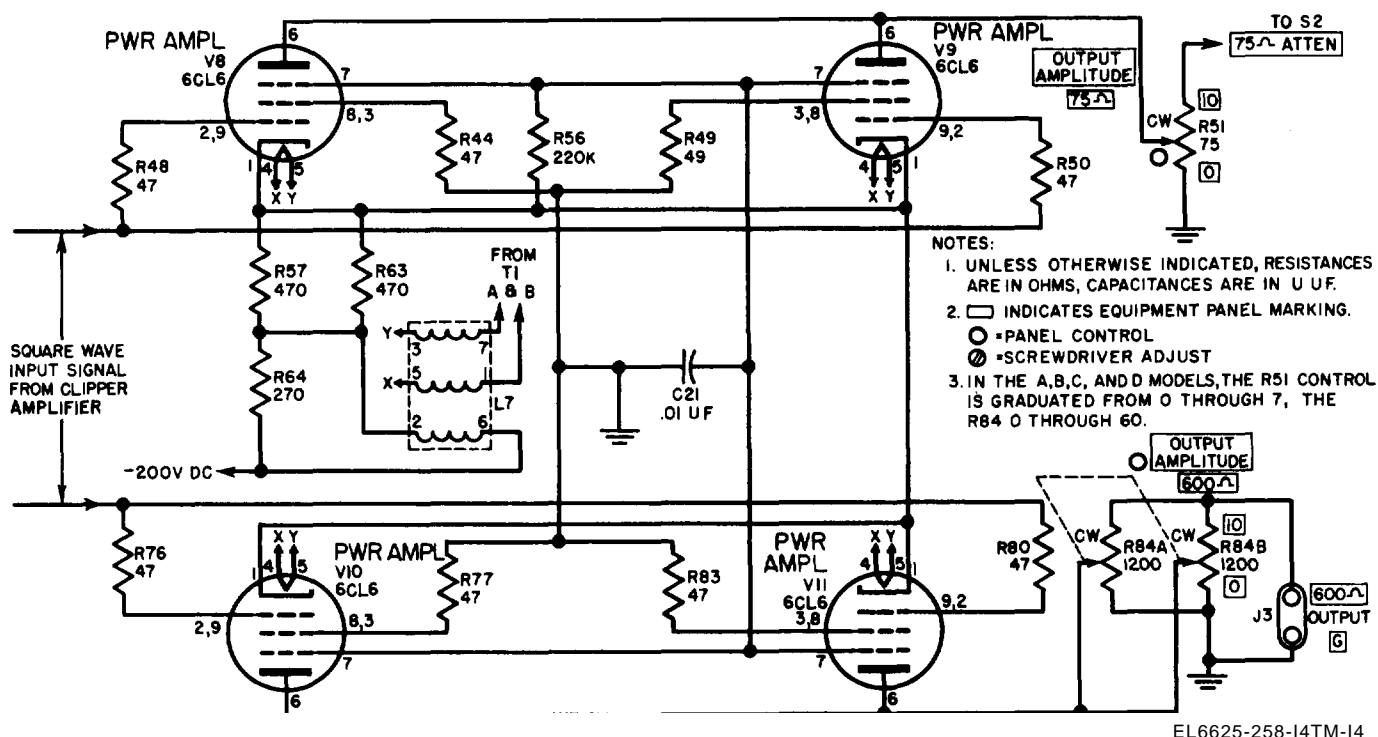

EL6625-258-14TM-14

Figure 5-6. Power amplifier circuit, simplified schematic diagram.

(3) The power tubes alternately switch from conduction to cutoff. Due to the heater-cathode capacitance, a transient effecting the leading and trailing edges of the waveform is introduced. A compensating network, consisting of resistors R57, R63, R64 and inductance unit L7, inserted in the common cathode circuit of the power amplifiers, introduces a corrective transient of opposite polarity to that produced by the interelectrode capacitance. The other sections of L7 are inserted in series with the filament circuits of the power amplifier tubes and keep radio frequency (rf) out of the filament line. Resistor R56 is a common suppressor resistor for the suppressor grids.

(4) Each half of the push-pull parallel power amplifier is connected to a separate output system. The output of V8 and V9 is connected to OUTPUT AMPLITUDE 75 Ω control R51 which adjusts the voltage input to the 75 Ω ATTN switch. The output of V10 and V11 is connected to the OUTPUT AMPLITUDE 600 Ω control R84A and R84B which adjusts the voltage level at 600-ohm output connector J3.

(5) Resistors R44, R49, R77, and R83 are parasitic resistors inserted in the screen grids of

the output tubes to minimize the effects of transients. Capacitor C21 bypasses the suppressor grids of the output tubes to ground.

b. 75 ATTN Switch (fig. 5-7). The 75 Ω ATTN switch is a three-section pi-type attenuator, each section introducing a 20-decibel (dB) loss when switched into the circuit. The switch has four positions.

(1) In the 0-DB position (fig. 5-7 shows the switch in the 60-DB position), the OUTPUT AMPLITUDE 75 Ω control is connected directly to 75 Ω output jack J2.

(2) In the 20-DB position, the 75-ohm signal is connected to the junction of voltage divider resistors R53 and R59. The voltage across R58 and C20 is connected to 75 Ω output jack J2.

(3) In the 40-DB position, the voltage across R58 and C20 is connected to the junction of voltage divider network C22, R66, and R68. The voltage across R69 and C26 is connected to 75 Ω output jack J2.

(4) In the 60-DB position, the voltage across R69 and C26 is connected to the junction of voltage divider network R72, R74, and C27. The voltage across R75 and C29 is connected to 75 Ω output jack J2.

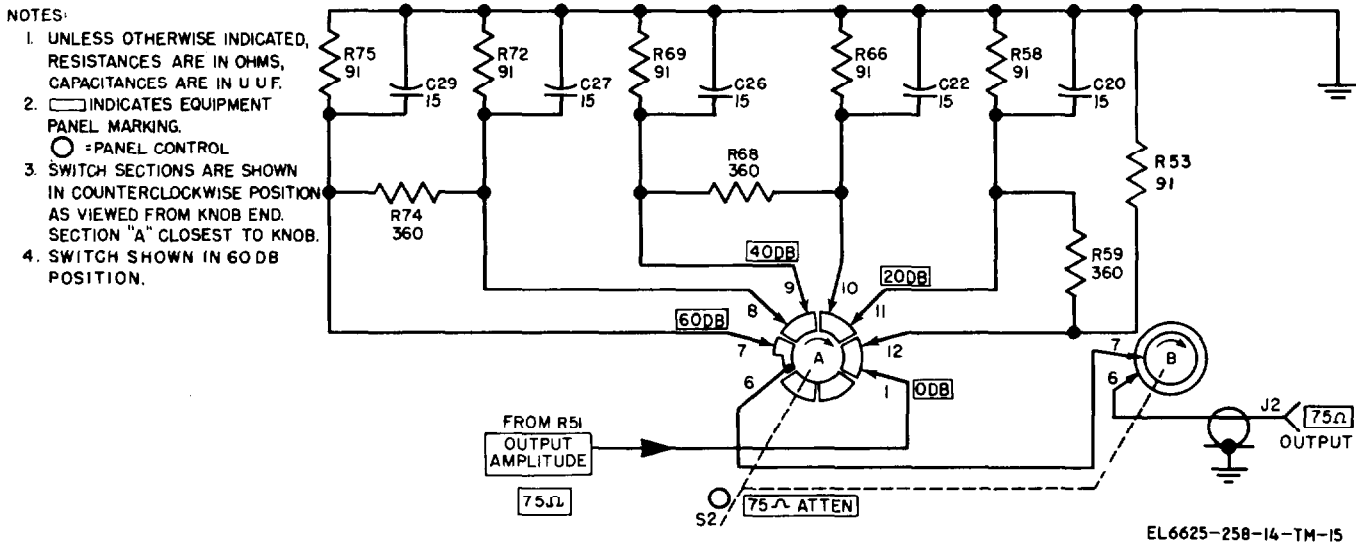

Figure 5-7. Attenuator switch schematic diagram.

5-8. **Power Supply**
(fig. 5-8)

To insure proper operation of the signal generator, it is essential that all dc voltages are regulated and free from ripple or noise. Special regulating features are, therefore, included in the power supply circuit. The following description covers the SG -299/U model only. Differences of other models are explained. For additional information see figures FO-4, FO-5, and FO-6.

a. Power transformer T1 supplies all of the ac voltages necessary for the operation of the signal generator. The primary of the power transformer consists of two windings normally wired in parallel for 115-volt operation. When 230-volt operation is required, the dual primaries are wired in series. The ac line voltage from P1 is fed through fuse F1 and power on switch S3 to the primary of T1, (In the A model, S3 is a double-pole switch. In the C and D models, fuse F1 and switch S3 are connected in series in the same line. Plug P1 has three prongs in the B, C, and D models; in the A model, supplied on order No. 4502-PP-60, the third prong is grounded to the chassis.) Fan B1 is connected across one primary winding of T 1 and provides forced ventilation for the signal generator. In the C and D models, a falter is inserted in the ac line. (The filter in the C model comprises a dual 0.1 μ F, 250-volt ac capacitor and the D model has a dual 0.01 μ F capacitor.) A type 5U4GB full-wave rectifier tube, V12, fed by the high-voltage winding of the transformer, provides an unregulated dc output voltage. Input filter C31 minimizes any ripple present in the output of the rectifier. (In the

unlettered model, C31 is comprised of one 40 μ F section and two 20 μ F sections connected in parallel. In the A and C models, C31 is comprised of two 40 μ F sections connected in parallel. In the B and D models, C31 is a single 80 μ F capacitor.)

b. A cathode follower regulator tube, V 13, is connected between the unregulated dc voltage and chassis ground. The cathode resistance of this tube is made up of resistors R91, R92, R94, R95, and R96 in parallel with the power supply load between chassis ground and the - 200-volt supply. Grid bias for control tube V14 is taken from the center arm of calibrating resistor R95. A change in the bias voltage of V 14 will result from any change in the voltage present between ground (chassis) and the - 200-volt output. Resistor R89 provides decoupling between the grids of V13, which are connected to the plate of V14. Resistor R86 is the plate load of V14 and screen voltage for this tube is taken from the junction of R85 and R90. Reference tube V 15 references the cathode of V14 to the - 200-volt output.

c. A change in the plate voltage of V14 will cause an identical change in the grid voltage of V13. The cathode follower action of V13 will then cause a corresponding change to take place between ground and the - 200-volt output. The plate voltage of V14 is determined by the bias voltage obtained from R95, which is controlled by the voltage across the regulated output; therefore, any tendency for the output voltage to change will be compensated by a change in bias voltage applied to the control grid of V14.

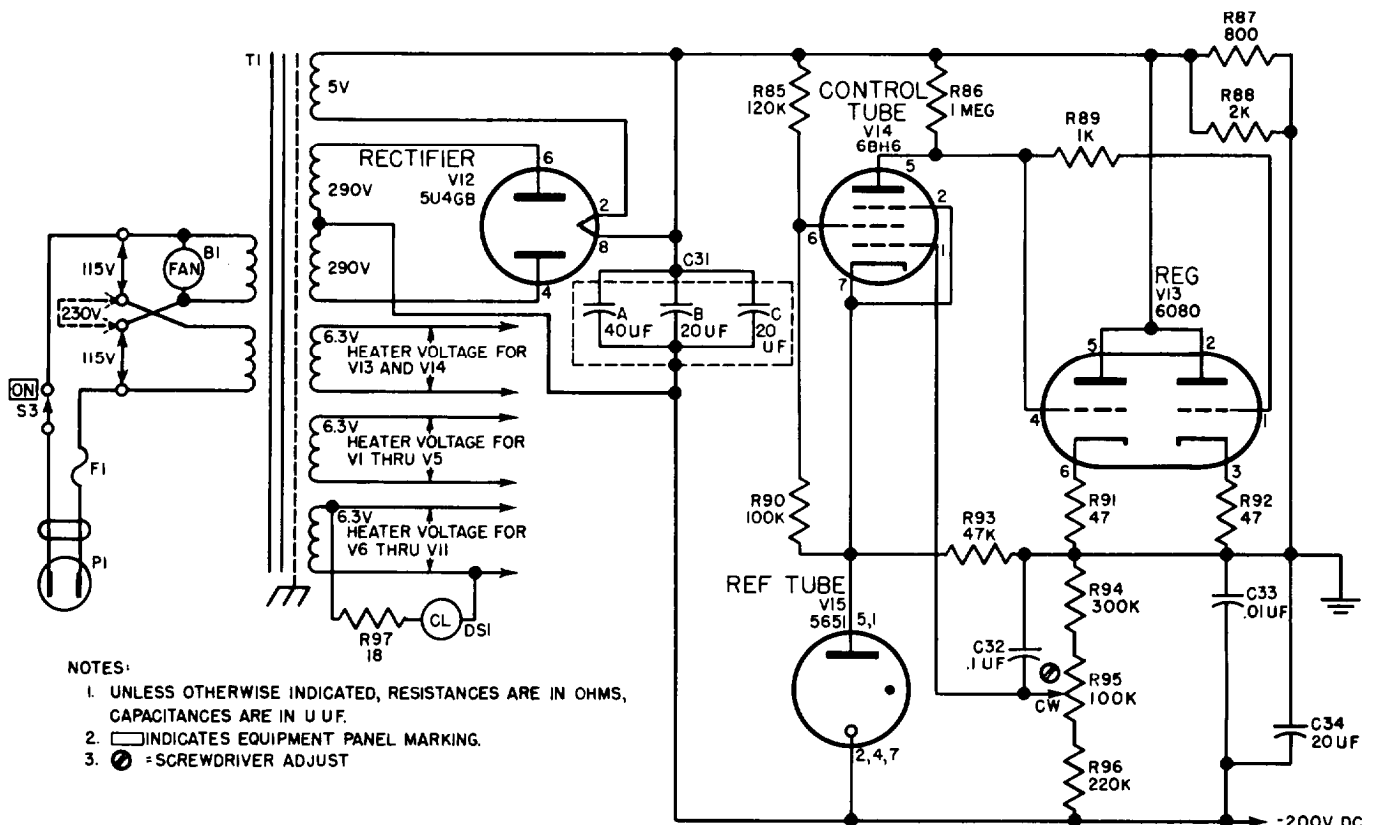

EL 6625-258-14-TM-16

Figure 5-8. Power supply circuit (SG-299/U model), simplified schematic diagram.

d. The shunting effect of resistors R87 and R88 prevents excessive current from passing through V13. A shunt path is also provided around V15 by R93. Resistors R91 and R92 provide decoupling between the cathodes of V13. Capacitors C32 and C33 prevent transients from effecting circuit operation. (Capacitor C33 is not used in the A model.) Additional filtering of the regulated output voltage is accomplished by capacitor C34. (In the A, B, C, and D models, capacitor C34 is 25 μ F.)

e. The output voltage can be adjusted by

calibration control R95. When the proper output of - 200 volts dc has been established, the regulating control circuits will maintain this voltage constant over a line voltage range of 105 to 125 volts ac (220 to 240 volts at).

f. The positive side of the power supply is connected to chassis ground. This permits direct coupling between the output amplifier plates and the output jacks without shock hazard.

g. Resistor R97 is connected in series with pilot lamp DS1 to limit the current through the pilot lamp.

CHAPTER 6

GENERAL SUPPORT MAINTENANCE

Section I GENERAL

6-1. Scope

The procedures for troubleshooting and general support maintenance of the signal generator are outlined in subsequent sections of this chapter. Where applicable, the procedures include instructions for making voltage and resistance measurements and instructions for replacing components when the procedure is not obvious. When making voltage and resistance measurements, observe the instructions in paragraph 6-2.

6-2. Voltage and Resistance Measurements**WARNING**

Be very careful when handling or testing

any part of the signal generator while it is connected to the power source. Certain points throughout the chassis operate at voltages above 250 volts. Do not touch these points while power is being applied to the signal generator.

Make all voltage and resistance measurements using Multimeter AN/USM-223, or equivalent, at the points specified in the troubleshooting table. To make measurements that are not specified in table 6-1, refer to the appropriate schematics and wiring diagrams to determine the test point desired.

Section II. GENERAL SUPPORT TOOLS AND TEST EQUIPMENT

6-3. Tools and Test Equipment

Tools and test equipment required for troubleshooting the signal generator are listed in Appendix C, Maintenance Allocation.

64. Special Tools and Equipment

No special tools or equipment are required.

Section III. TROUBLESHOOTING

6-5. Organization of Troubleshooting Procedures

a. General. The first step in servicing a defective signal generator is to sectionalize the fault. Sectionalization means tracing the fault to one of the major circuits responsible for the abnormal operation. The second step is to localize the fault. Localization means tracing the fault to a particular stage or network within one of the major circuits. The third step is to isolate the fault. Isolation means tracing the fault to the defective part responsible for the abnormal condition. Some faults, such as burned-out resistors, arcing, and shorted transformers often can be located by sight, smell, and hearing. The majority of faults, however, must be isolated by checking voltages and resistances.

b. Component Sectionalization, Localization, and Isolation. Listed below is a group of tests

arranged to simplify and to reduce unnecessary work and to aid in tracing a trouble to a specific component. Follow the procedure in the sequence given. A serviceman must be careful not to cause further damage to the signal while it is being serviced.

(1) *Visual inspection.* The purpose of visual inspection is to locate faults without testing or measuring circuits. All visual signs should be observed and an attempt made to sectionalize the fault to a particular function.

(2) *Operational tests.* Operational tests frequently indicate the general location of trouble. In many instances, the tests will help in determining the exact nature of the fault. The daily maintenance service and inspection table (4-1) contains a good operational test.

(3) *Troubleshooting table.* The troubleshooting table (6-2) lists symptoms of

common troubles and gives (or references) corrective measures. Such a table obviously cannot include all trouble symptoms that may occur. The repairman should use this chart as a guide in analyzing symptoms that may not be listed.

(4) *Voltage and resistance measurements.* Take voltage measurements at the tube sockets related to the stage in question (fig. 6-1 or 6-2). Where abnormal voltage reading is obtained, take resistance measurements.

(5) *Intermittent troubles.* In all the tests, the possibility of intermittent troubles should not be overlooked. If present, this type of trouble often may be made to appear by tapping or jarring the equipment. It is possible that some external connections may cause trouble. Test wiring for loose connections; move wires and components with an insulated tool, such as a pencil or fiber rod. This may show where a faulty

connection or component is located. Minute cracks in printed circuit boards can cause intermittent operation. A magnifying glass is often helpful in locating defects in printed boards. Make continuity measurement of printed conductors.

c. *Visual Inspection.* Failure of the signal generator to operate properly can often be traced to one or more of the following faults:

(1) Improperly connected power cable, or no voltage at the outlet into which the power cable is connected.

(2) Burned-out fuse.

(3) Broken wires.

(4) Defective tubes.

(5) Improperly connected output or input cables.

(6) Worn, broken, or disconnected cords or connectors.

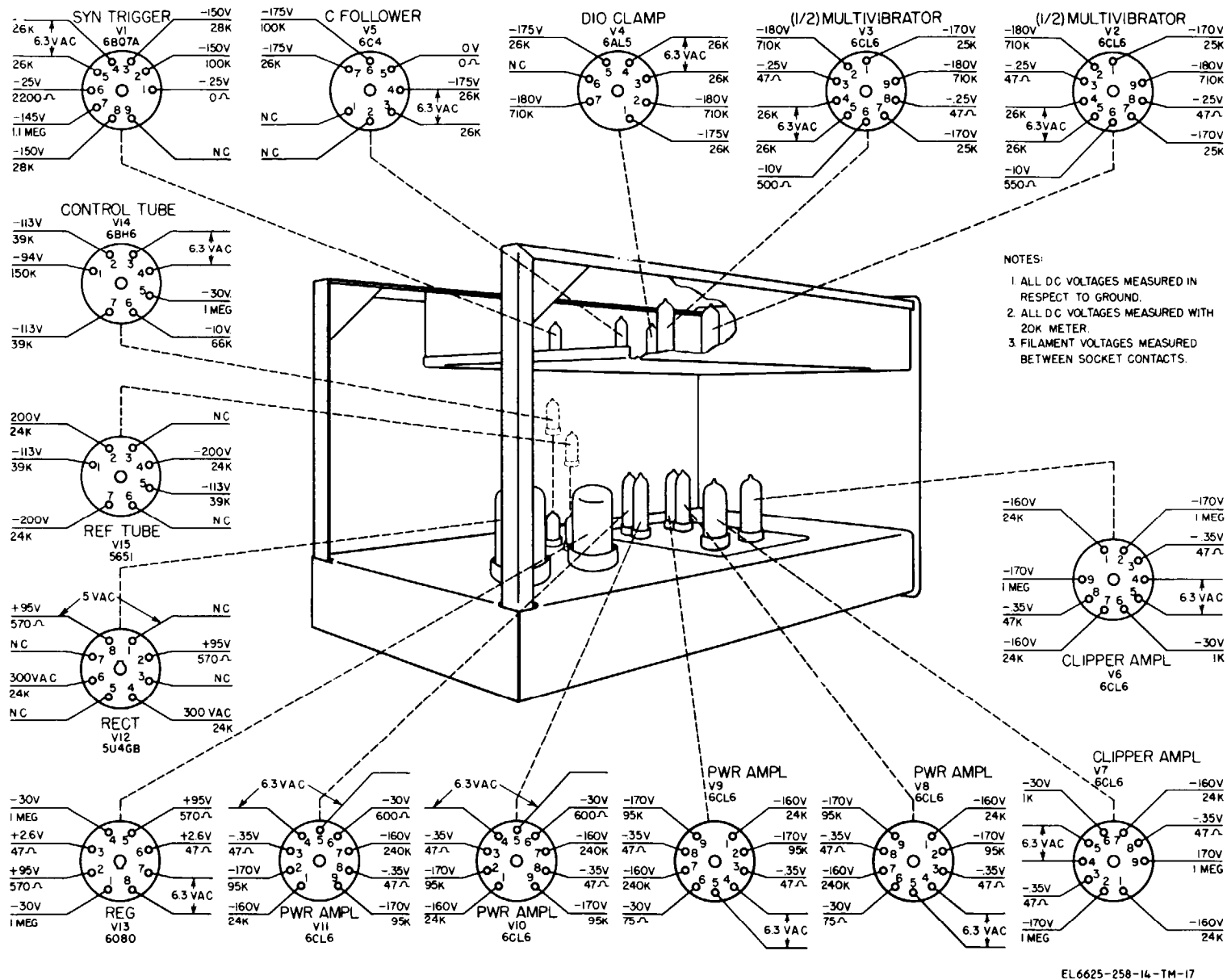
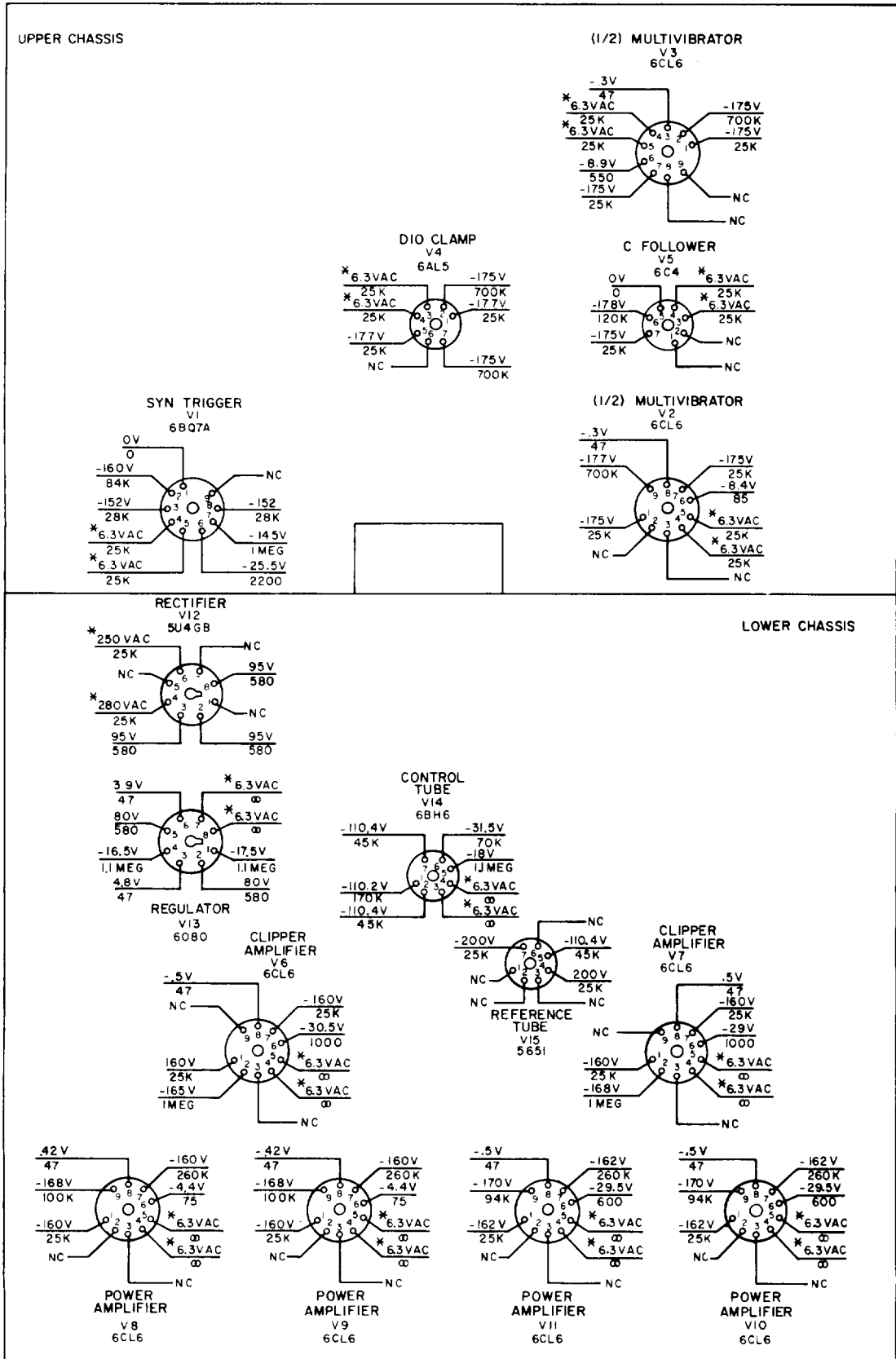

Figure 6-1. Tube socket voltage and resistance diagram (unlettered, B, D, and E models).



6-6. Checking Plate Voltage Supply Circuits for Shorts

a. *When to Check.* When any of the following conditions exist, check for short circuit and clear the troubles before applying power.

(1) When abnormal symptoms reported from operational tests indicate possible power supply trouble.

(2) When the nature of the abnormal symptoms is not known.

(3) When the abnormal symptom reported is no output.

b. *Conditions for Tests.* Prepare for the short circuit tests as follows:

(1) Remove the equipment from its case.

CAUTION

Do not rock or rotate a tube when removing it from a socket; pull the tube straight out with a tube puller. Failure to comply may result in damage to the tube or socket.

(2) Remove all tubes.

NOTE

When the short circuit tests have been made, replace the tubes.

c. *Measurements.* Make the resistance measurements indicated in the following table (6-1). If abnormal results are obtained, make the

additional isolating checks outlined. When the faulty part is found, repair the trouble before applying power to the unit.

6-7. Localizing Troubles

a. *General.* The troubleshooting table (6-2) is supplied as an aid in locating various types of trouble in the signal generator. When the trouble has been localized to a particular stage, use isolating technique (para 6-8) to find the defective part. Normal volt age and resistance readings are given in figures 6-1 and 6-2. Part locations are indicated in figures 6-3 through 6-14.

b. *Use of Table.* When an abnormal symptom has been observed in the equipment, look for a description of this symptom in the *Malfunction* column and perform the corrective measure in the *Corrective* action column. If no operational symptoms are known, begin with Table 4-1 (Daily Preventive Maintenance Checks and Services) and proceed until a trouble symptom appears.

CAUTION

If operational symptoms are not known, or if they indicate the possibility of short circuits within the signal generator, make the short circuit checks described in paragraph 6-6 before applying power to the unit.

Table 6-1. Short Circuit Tests

<i>Point of measurement</i>	<i>Normal indication</i>	<i>Isolation procedure</i>
From pins 2, 4, or 7 of V15 to chassis ground.	Approximately 24,000 ohms.	If resistance is zero or low, check capacitors C11, C25, C31, C33, and C34 for direct short or leakage. Also check for shorted wiring.
Pin 1 of V8, V9, V10 or V11 to chassis ground.	More than 24,000 ohms.	If resistance is low, check C21,

Table 6-2. Troubleshooting

<i>Malfunction</i>	<i>Probable cause</i>	<i>Corrective action</i>
1. Dc voltage between chassis and test point on R39 (fig. 6-3 or 6-4) measured with Differential Voltmeter AN/USM-98 is: Less than 200V	Defective V12 or V13,	Replace V12 or V13. Adjust R95 (para 6-12).
Greater then 200 V	Defective V14	Replace V14. Adjust R95 (para 6-12).
Erratic	Defective V15	Replace V15. Adjust R95 (para 6-12).
2. Waveform at 75-ohm output nonsymmetrical. Cannot be corrected by adjustment of symmetry control.	Defective V2 or V3,	Replace V2 or V3. Readjust X100 range (para 6-13).
3. Waveform at 75-ohm output with signal generator set for 1,000 Hz has rounded leading edge.	Defective V6, V8, or V9	Replace tube.

Table 6-2. Troubleshooting— Continued

Malfunction	Probable cause	Corrective action
4. Waveform at 75-ohm output less than 7V peak-to-peak; 600-ohm output at its rated value.	Defective V6, V8, or V9.	Replace tube.
5. Output signals at both 75-ohm and 600-ohm outputs less than rated values.	Defective V6 and/or V7. Power supply.	Replace tube. Refer to step 1.
6. Top of waveform slopes when signal generator frequency is set for 20 Hz.	Defective V2 or V3. Defective V6 through V11.	Replace tube and readjust X100 range (para 6-13). Replace as necessary. No adjustment required.
7. Waveform at 600-ohm output with signal generator set for 1,000 Hz has rounded leading edge.	Defective V7, V10 or V11.	Replace tube.
8. Voltage at 600-ohm output less than 55V peak-to-peak; 75-ohm output at its rated value.	Defective V10 or V11.	Replace tube.
9. Waveform at 600-ohm output with signal generator set for 20 Hz has sloping top.	Defective V2 or V3.	Replace tube. Readjust X100 range (para 6-13).
10. No synchronization with external 1,000-Hz, 5-V peak signal applied to SYNC IN jack.	Defective V1.	Replace tube. Adjust sync sensitivity (para 6-14).
11. Sync will not hold over frequency range from 1,000 to 950 Hz.	Defective CR1 or V1.	Replace defective component and adjust sync sensitivity (para 6-14).
12. Fuse F1 blows when equipment is turned on.	Shorted C31	Check C31, C11, C25, C33, and C34.
13. Indicator lamp DS1 does not light and no signal is obtained from 75-ohm output or 60-ohm output,	No ac power is being applied to power supply.	Check line switch S3 for continuity. Check the dual primary of transformer T1. Check fuse F1. If fuse is blown, check capacitors listed in item 12 above.
14. Pilot lamp and tubes light, but no signal is obtained from 75-ohm or 600-ohm output.	Failure of — 200-volt supply. Defective V2 or V3	Check capacitor C34 and all bypass capacitors across — 200 volt supply. Check L1 and L4. Measure the voltage and resistance from pins of V2 and V3 to ground; compare these readings with figure 6-1 or 6-2.
15. No signal is obtained from 75-ohm output; 600-ohm output is normal.	Open cable from J2 or 75 ohm ATTEN control. Defective jack J2. Open cable between 75-ohm ATTEN control and the 75-ohm output amplifier tube control. Defective OUTPUT AMPLITUDE control R51.	Replace or repair cable. Replace jack J2. Replace or repair cable. Check R51.
16. Signals from 600-ohm output and 75-ohm output are only half of rated output.	Open L7. Defective R61.	Check L-7 (para 6-9), Check cathode resistor R61. for increase in resistance
17. Signal is at its rated value at both outputs, but has a distorted waveshape as shown in A, figure 6-15.	Defective frequency compensating capacitors C18 or C30.	Check C18 or C30.
18. Signal is at its rated value at both outputs, but has a distorted waveshape as shown in B, figure 6-15.	Defective C23 or C24.	Check C23 and C24.
19. Signal is reduced 50% at the 75-ohm output, 600-ohm output is less than 3 volts peak-to-peak and appears as shown in C, figure 6-15.	Defective R79	Check R79.

Table 6-2. Troubleshooting— Continued

<i>Malfunction</i>	<i>Probable cause</i>	<i>Corrective action</i>
20. Signal is reduced 50% at the 600-ohm output; signal from the 75-ohm output is zero.	Defective R47.....	Check R47.
21. Signal from the 600-ohm output is as shown in E, figure 6-16; 75-ohm output is only 3 volts peak-to-peak and appears as in D, figure 6-15.	Defective R62.	Check R62.
22. Signal from 75-ohm output is as shown in E, figure 6-15; 600-ohm output is only 20 volts peak-to-peak and appears as in D, figure 6-15.	Defective R67.	Check R67.
23. Output amplitude at its rated value, but both 600-ohm and 75-ohm outputs distorted as in F and G, figure 6-15.	Defective C28 or C19.....	Check C28 and C19.
24. No signal is obtained from the 600-ohm output; 75-ohm output is at its rated value.	Defective cable from J3 to output amplitude control.	Check cable.
25. Unable to adjust signal generator.	Defective R18, R15, or R26	Check R18, R15, and R26. Readjust (para 6-13).
26. FREQUENCY control has no effect.	Defective FREQUENCY control R9	Check R9. Readjust (para 6-13).
27. Unable to adjust one range or no output on one range.	Defective R70 or R13 Defective resistor or capacitor in RC network associated with that range.	Check R7 and R8. Refer to figure 5-2 and check components associated with defective range.
28. Unable to synchronize multivibrator with external synchronizing signal.	Defective cable from J1 to C8.	Check cable. Check voltage and resistances from socket pins of V1 to ground. Compare with values shown in figure 6-1 or 6-2.

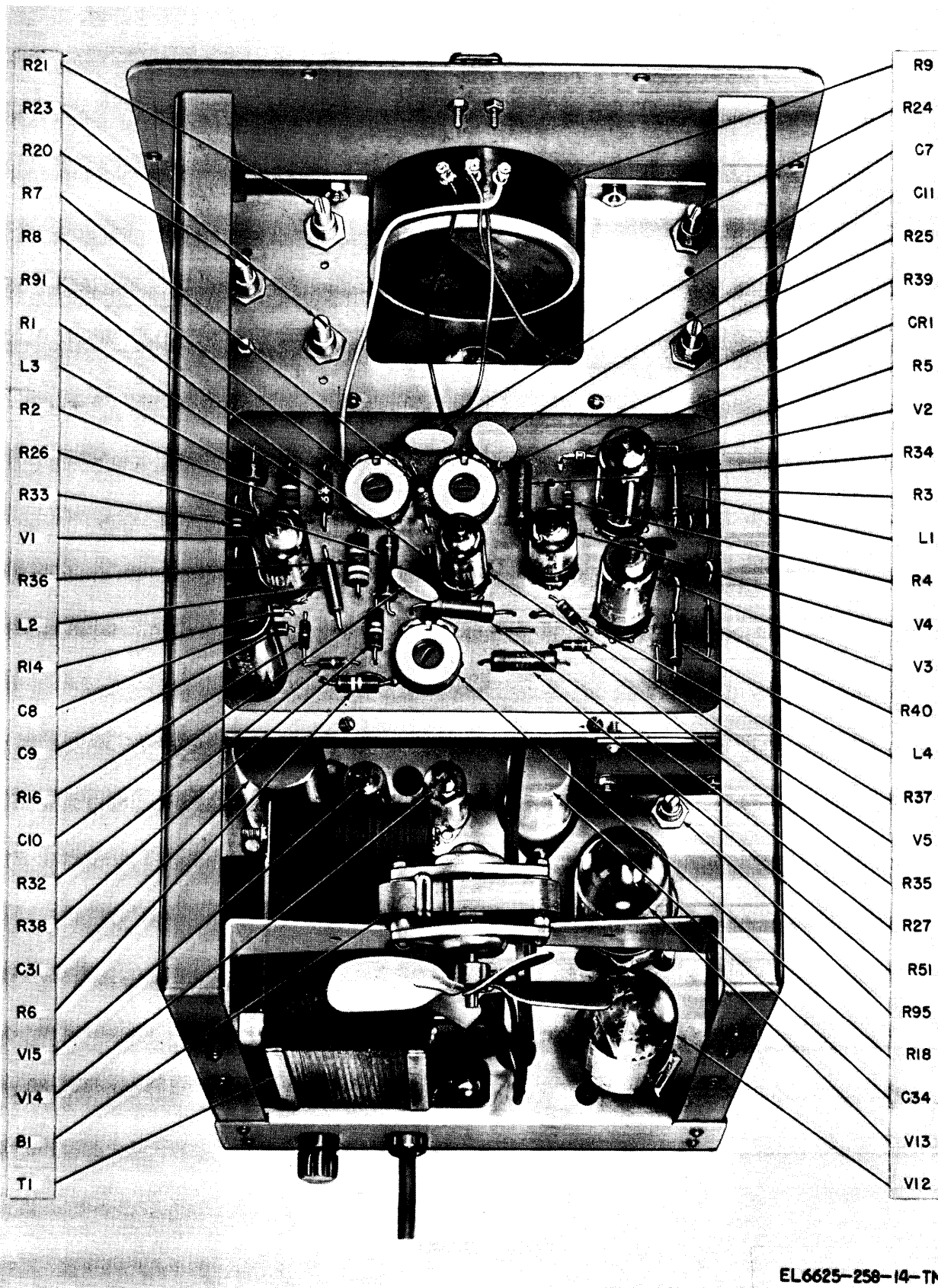

EL6625-258-14-TM-19

Figure 6-3. Signal Generator SG-299/U, parts location, top view.

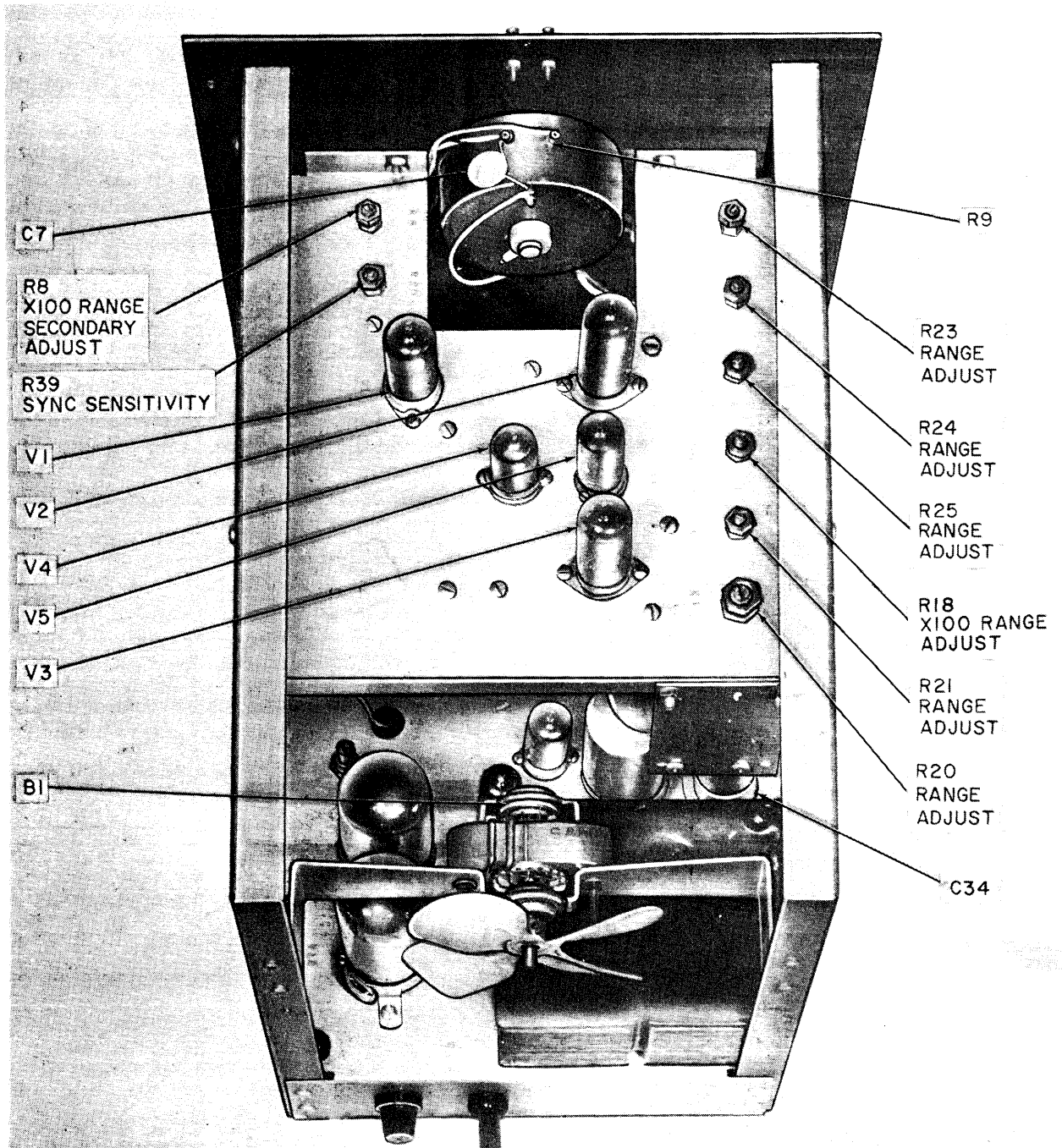

EL6625-258-14-TM-20

Figure 6-4. Signal Generator SG-299A/U, adjustments.

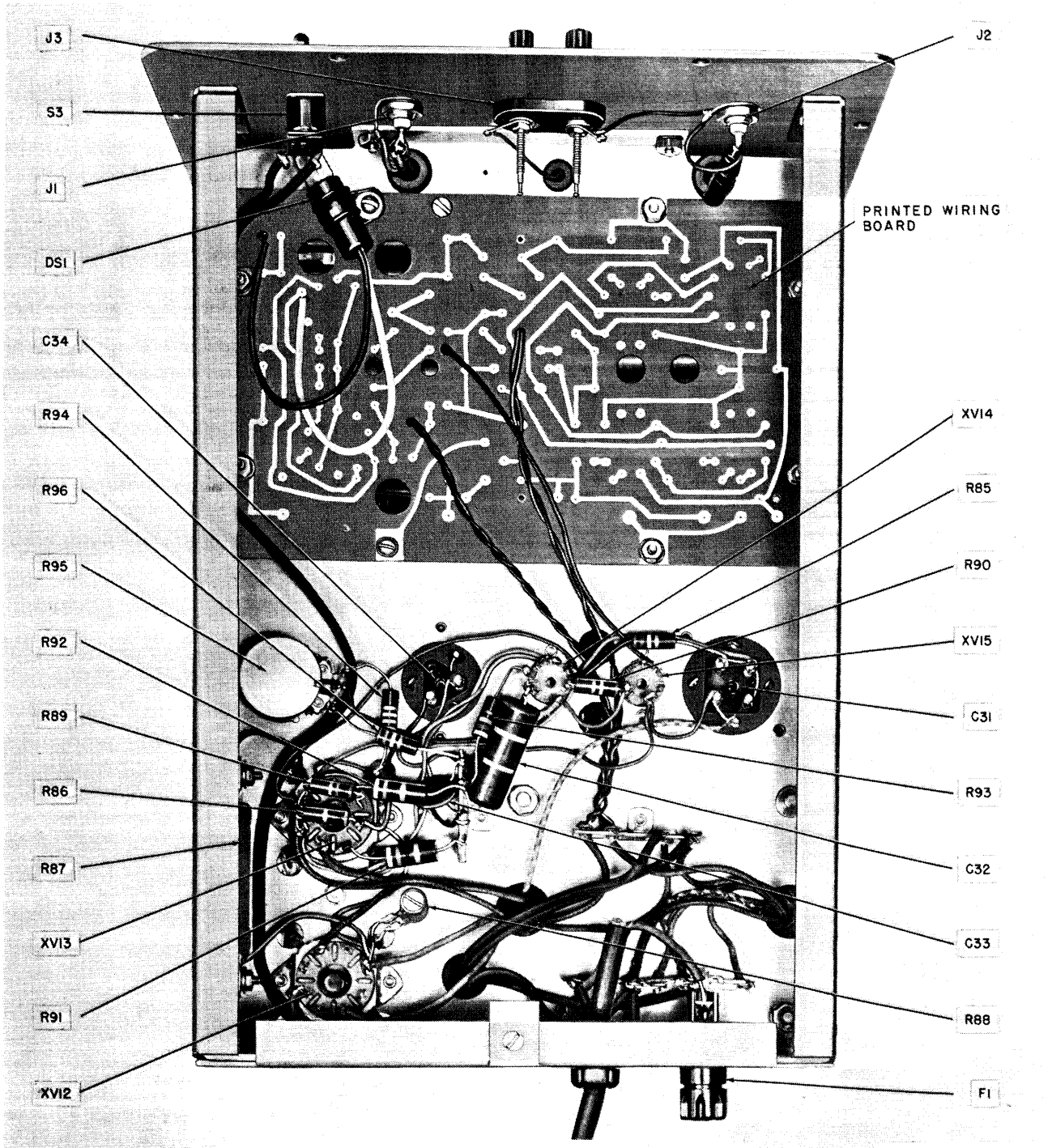

EL6625-258-14-TM-21

Figure 6-5. Signal Generator SG-299/U, parts location, bottom view.

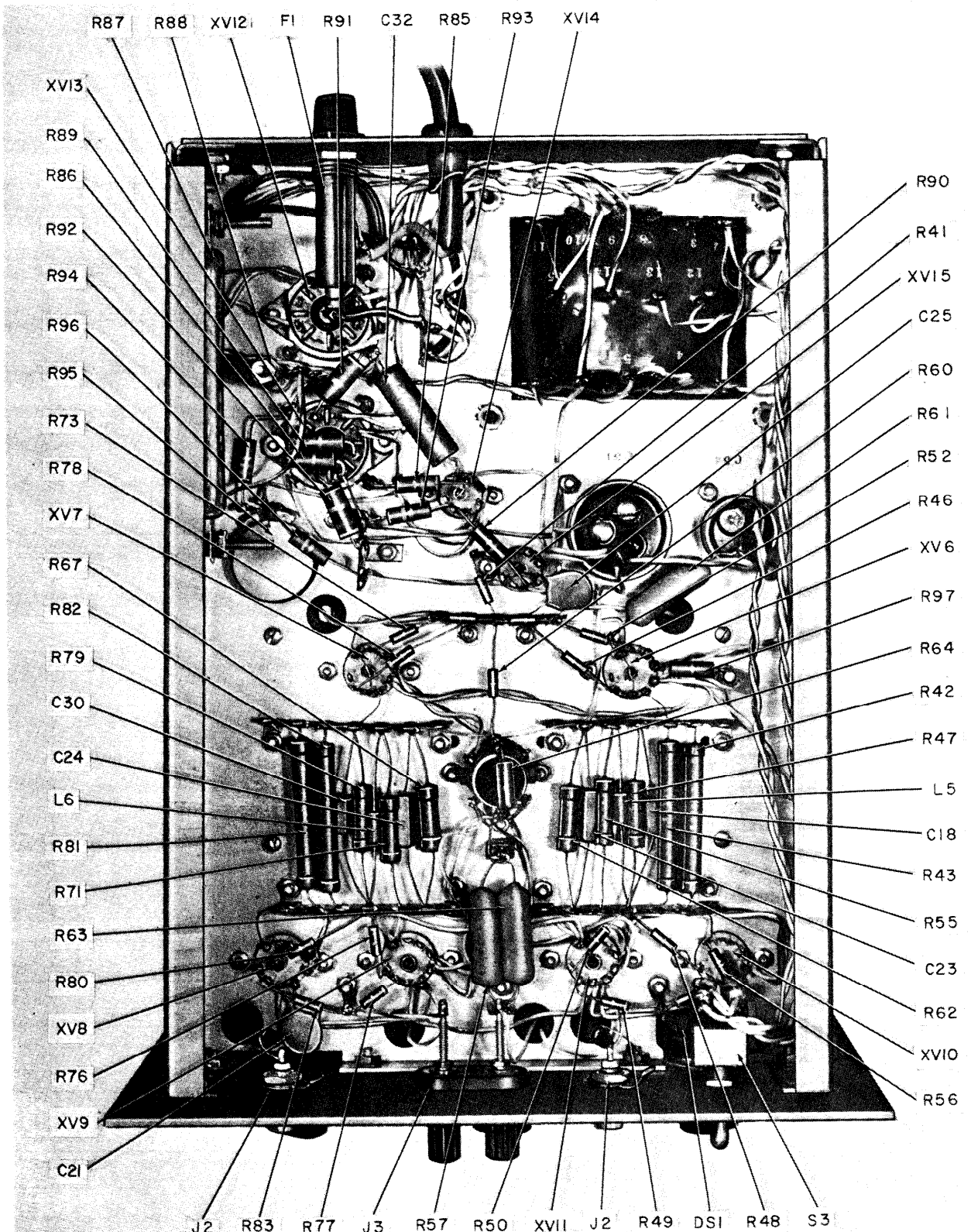

EL6625-258-14-TM-22

Figure 6-6. Signal Generator SG-299A/U.

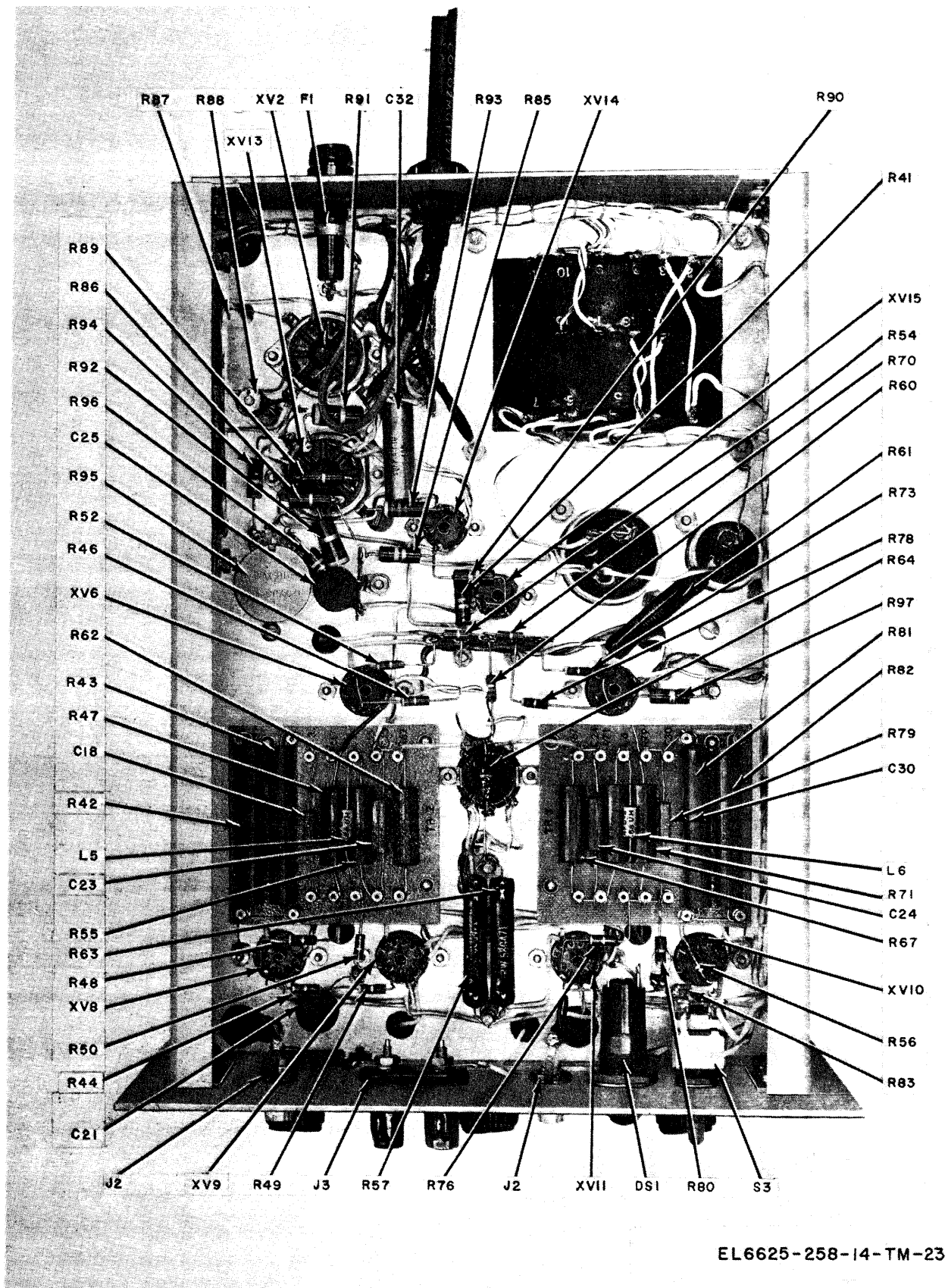

EL6625-258-14-TM-23

Figure 6-7. Signal Generator SG-299A/U (Order No. 4502-PP-60 and SG 299C/U, parts location, bottom view.

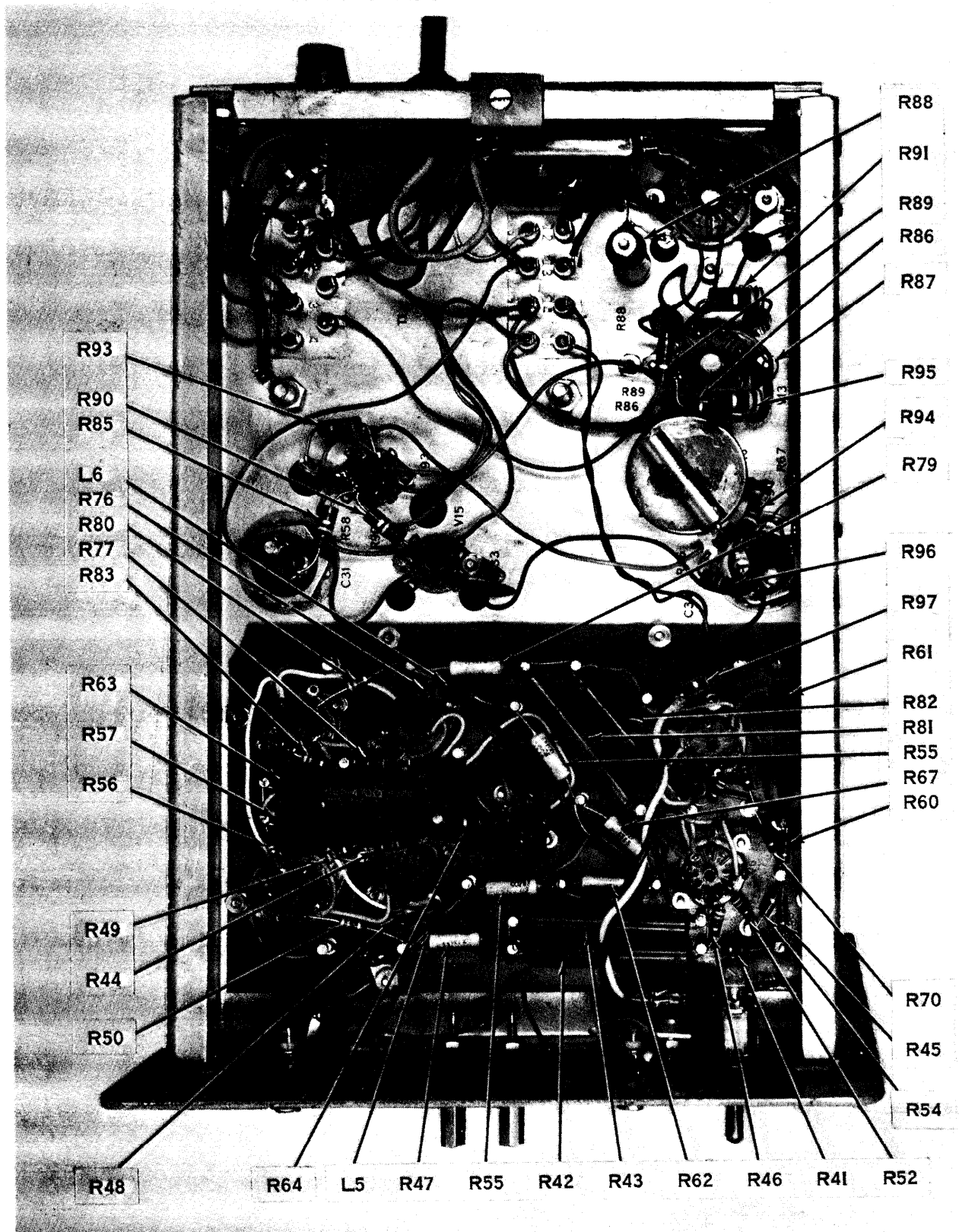

EL6625-25814-TM-24

Figure 6-8. Signal Generator SG-299B/U, SG-299D/U, and SG-299E/U, parts location, bottom view, part 1.

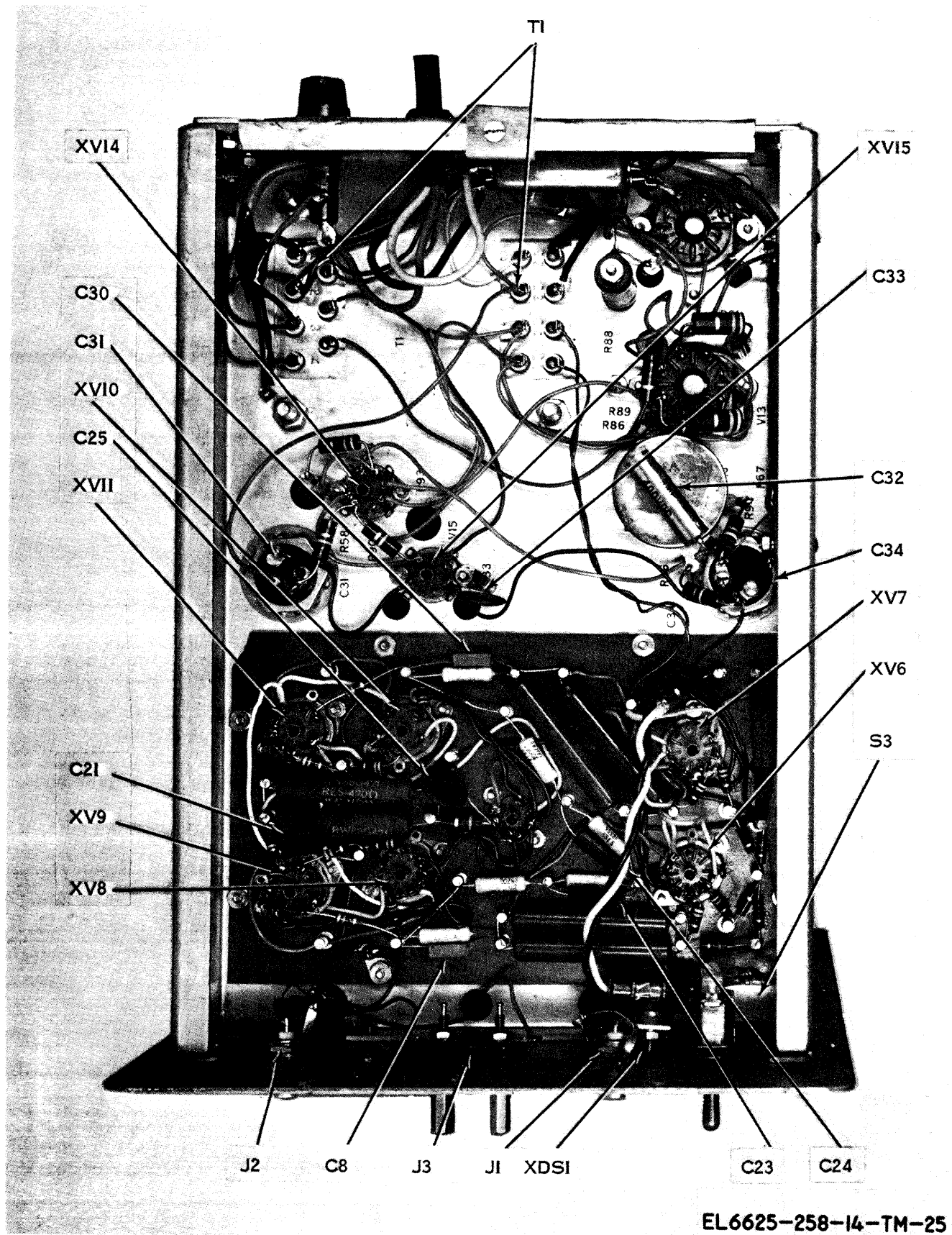

EL6625-258-14-TM-25

Figure 6-9. Signal Generator SG-299B/U, SG-299D/U, and SG-299E/U, bottom view, part 2.

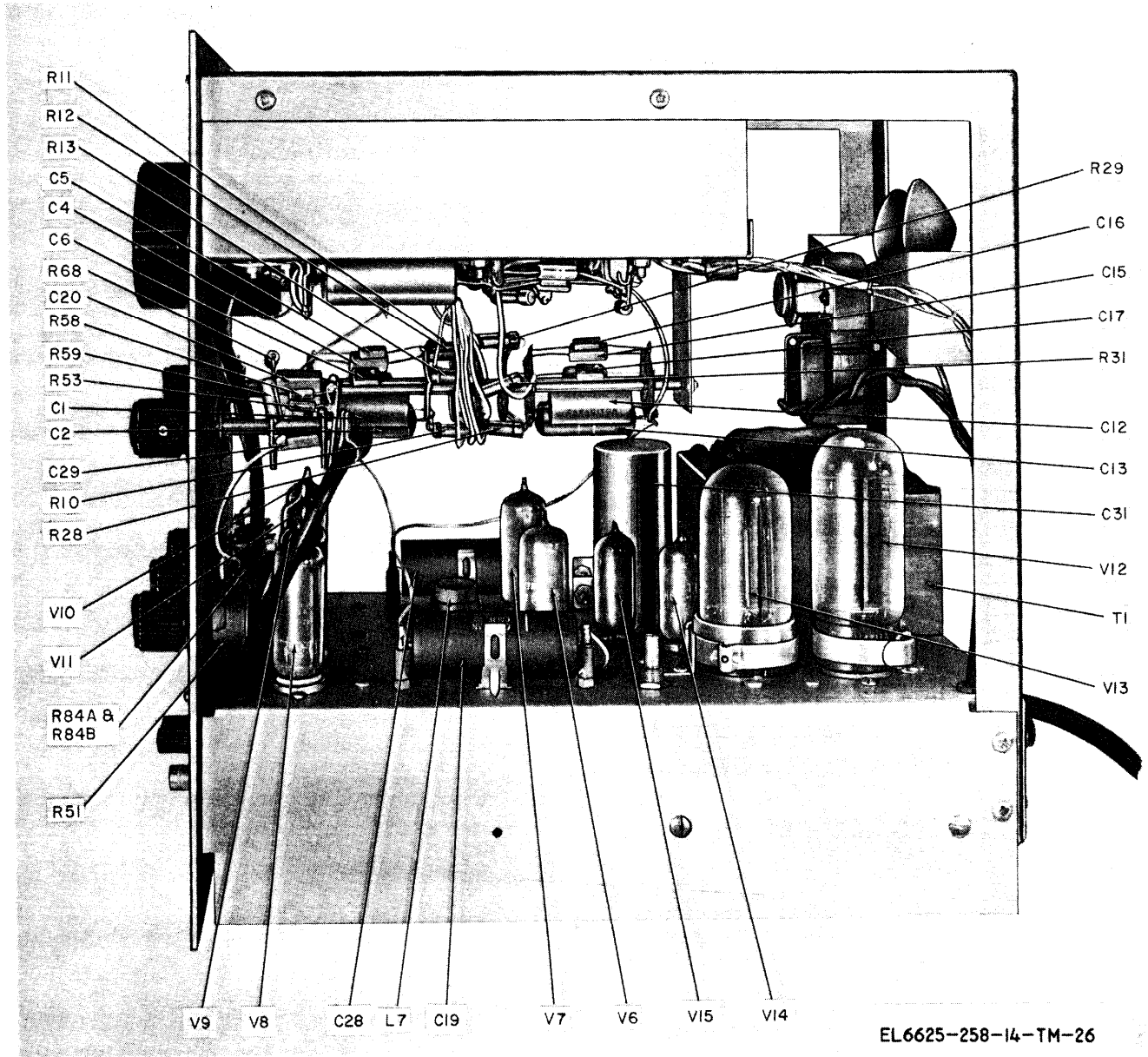
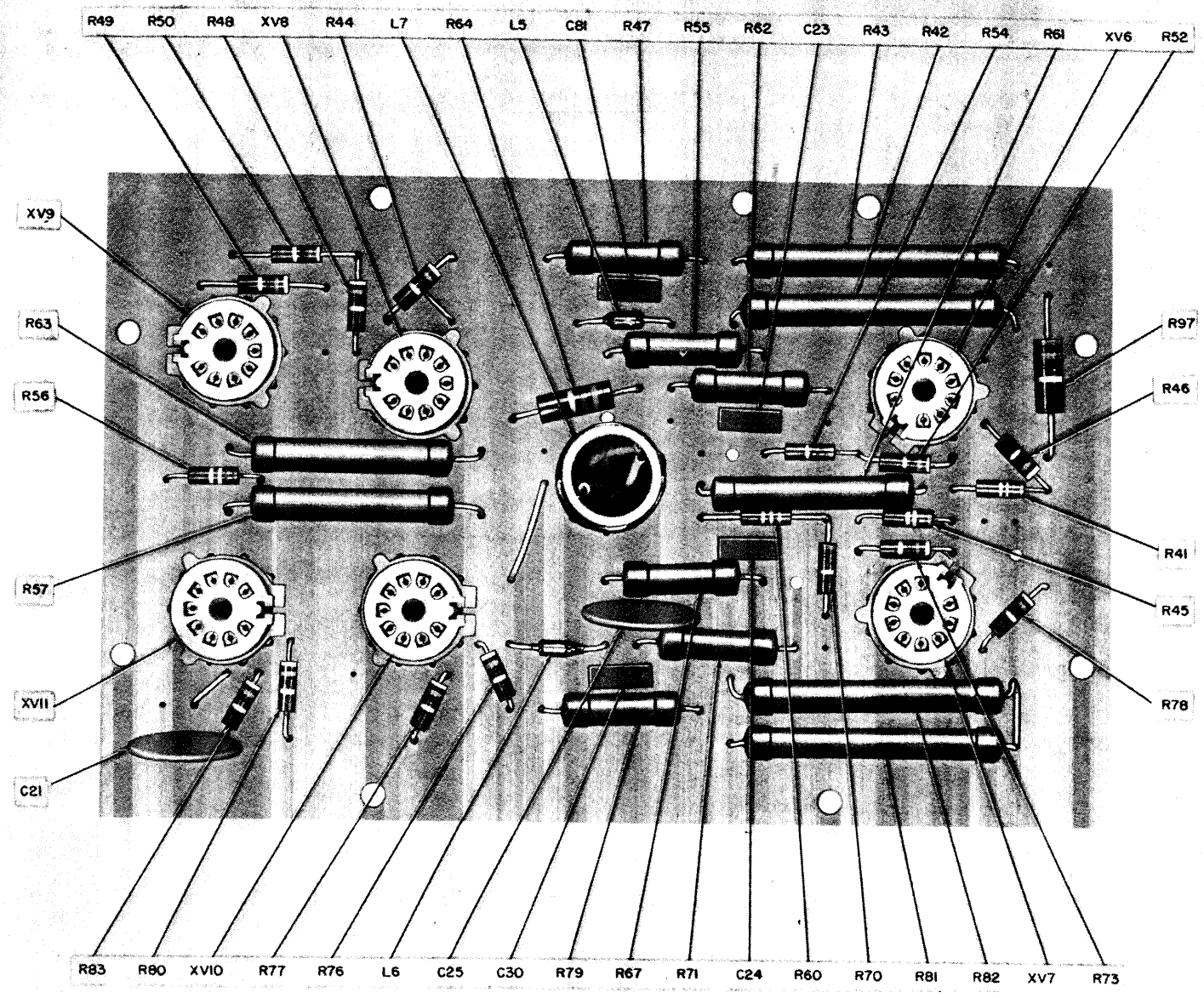

Figure 6-10. Signal Generator SG-299A/U, parts location, side view.



EL6625-258-14-TM-27

Figure 6-11. Signal Generator SG-299A/U, parts location, terminal board.

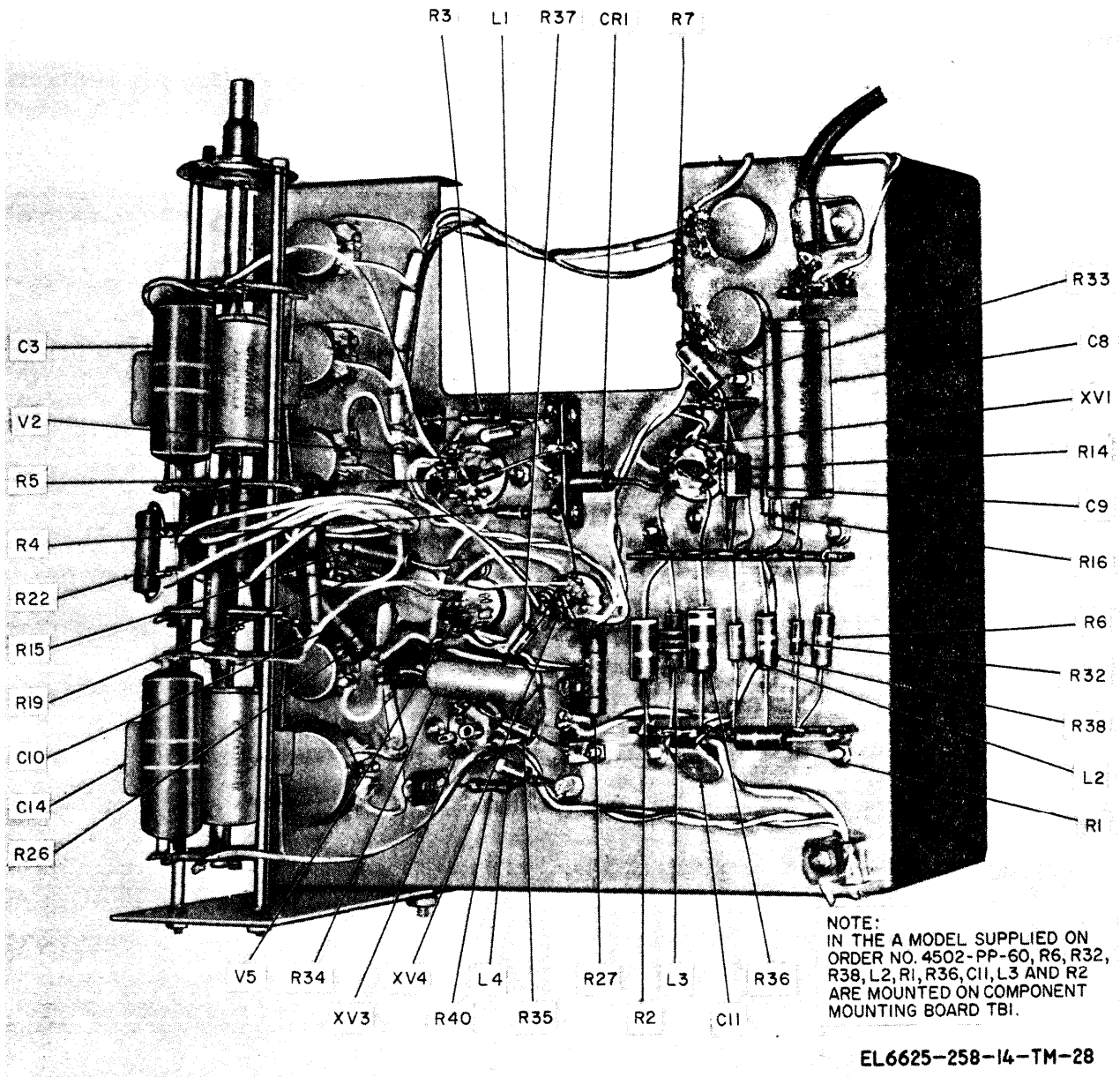
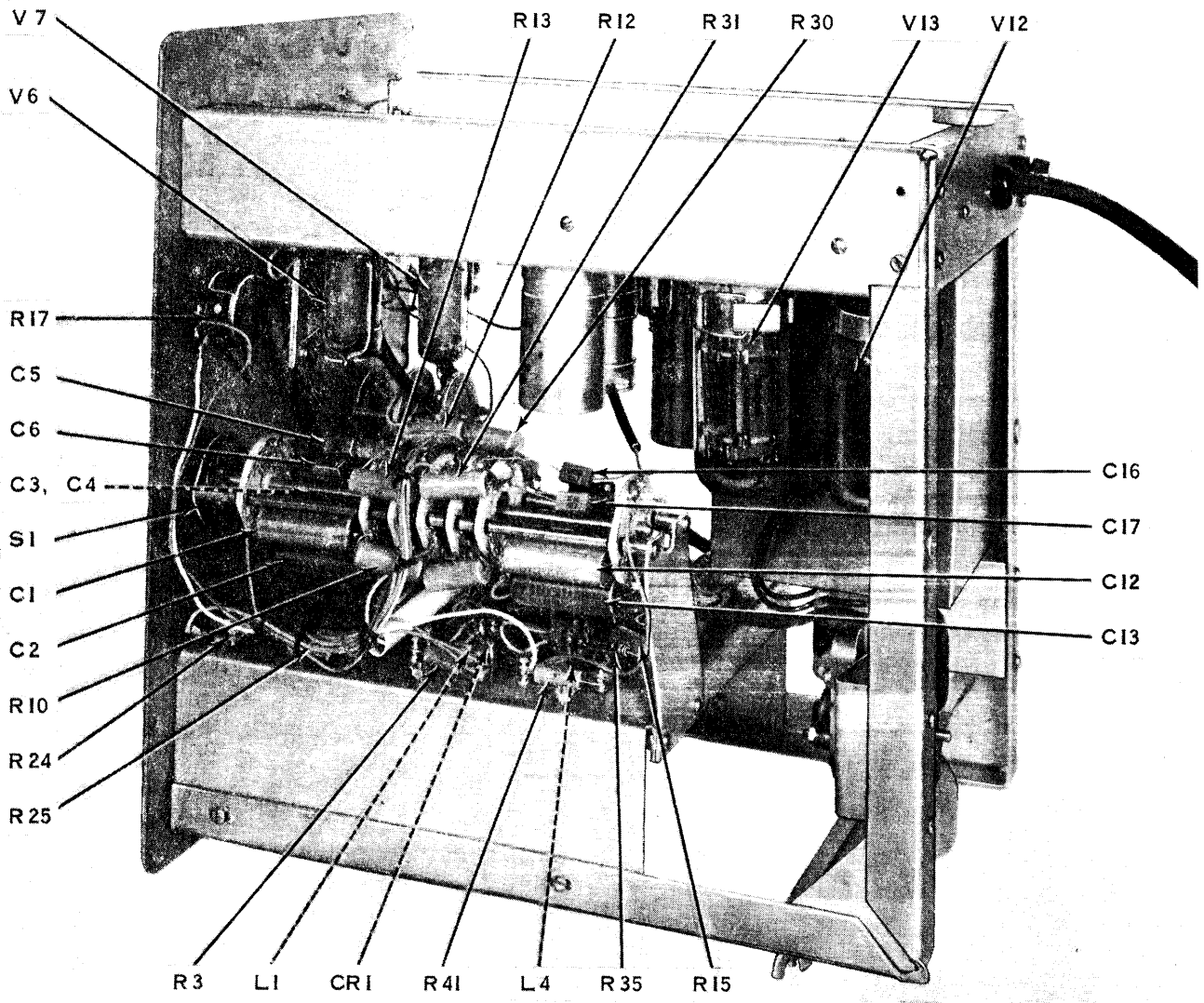
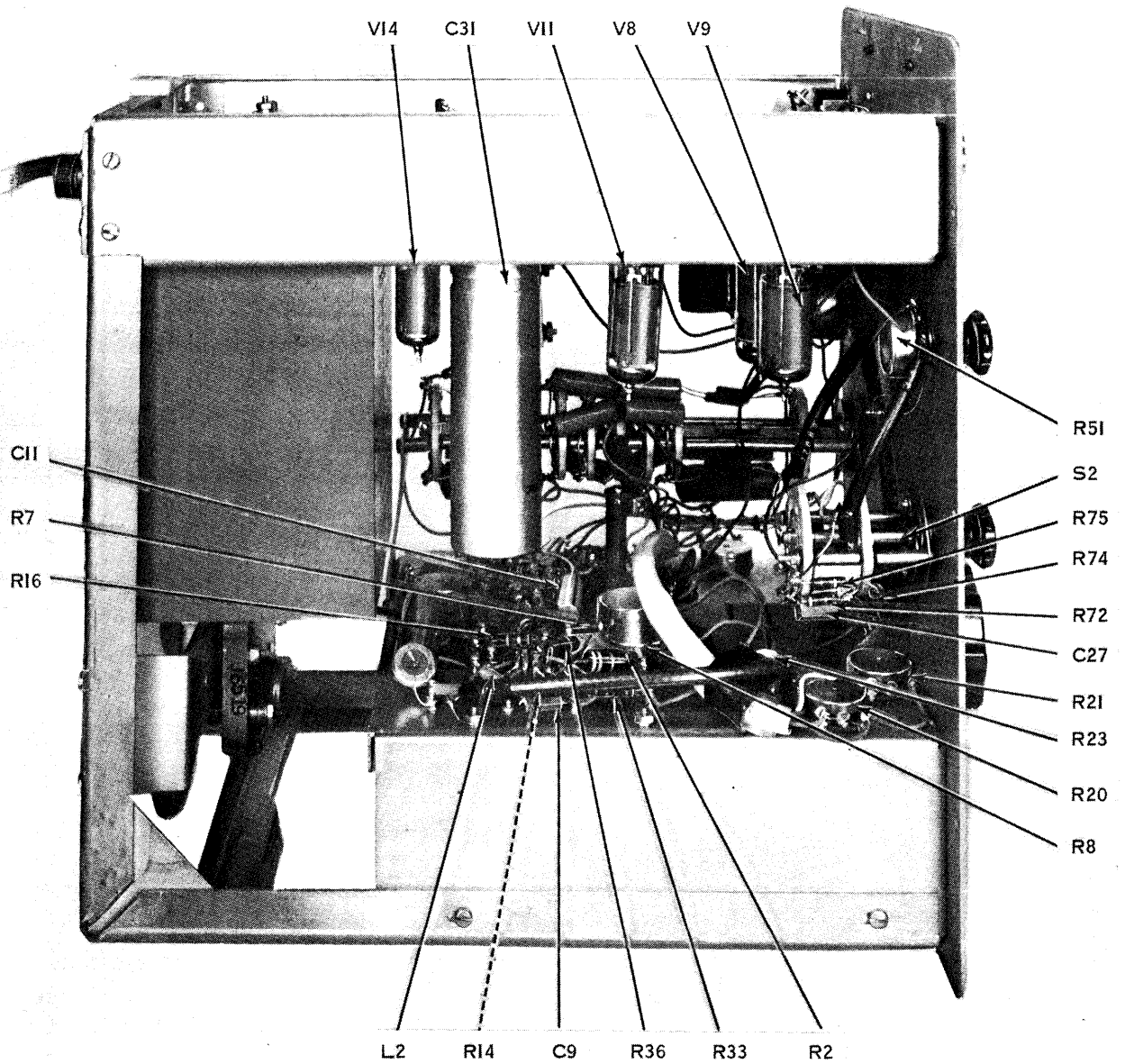

Figure 6-12. Signal Generator SG-299A/U sync trigger and multivibrator chassis, parts location, top view.



EL6625-258-14-TM-29

Figure 6-13. Signal Generator SG-299B/U, SG-299D/U, and SG-299E/U sync trigger and multivibrator chassis, parts location, left side view.



EL6625-258-14-TM-30

Figure 6-14. Signal Generator SG-299B/U, SG-299D/U, SG-299E/U sync trigger and multivibrator chassis, parts location, right side view.

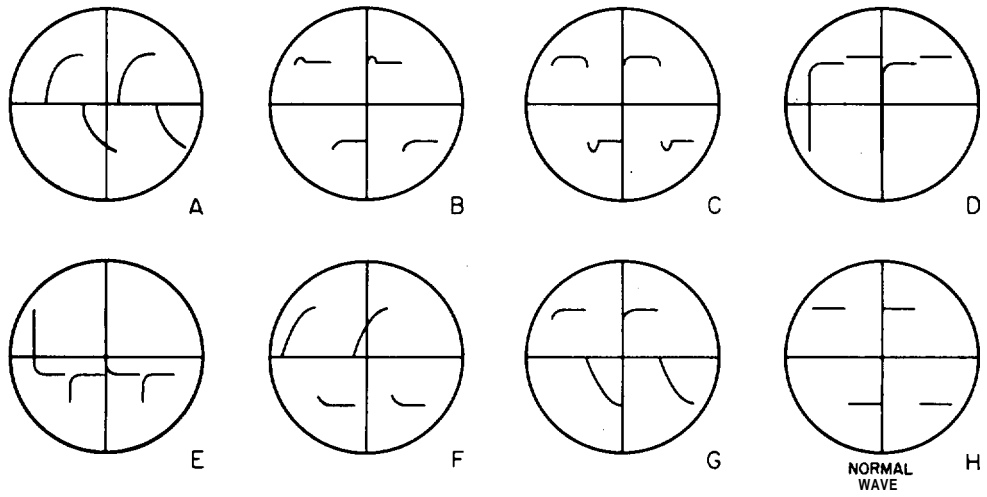

EL6625-258-14-TM-31

Figure 6-15. Waveforms for use with troubleshooting table.

6-8. Isolating Techniques

When trouble has been localized to a stage, use the following techniques to isolate the defective part:

- a. Test the tube involved by substituting a similar type of tube which is known to be good. Refer to paragraph 4-12.
- b. Take voltage measurements (fig. 6-1 or 6-2).
- c. If voltage readings are abnormal, take resistance readings (fig. 6-1 or 6-2). Refer also to the dc resistances of transformers and coils in paragraph 6-9.

6-9. Dc Resistances of Transformer and Coils

a. The dc resistance data (b below) is provided as an aid to troubleshooting. When using the data, observe the following:

- (1) Before making resistance measurements

of the windings, determine that faulty operation is very likely due to a faulty transformer or coil. To do this, follow the troubleshooting procedure (para 6-6 through 6-8) and make voltage and resistance checks (fig. 6-1 or 6-2),

(2) Do not use the resistance measurements as the sole basis for discarding a transformer or coil as defective. Bear in mind that, due to rather broad winding tolerances during manufacture, resistances may vary from one transformer or coil to another; the chart values are typical average values.

(3) The normal resistances of replacement transformers and coils may differ greatly from the values given in the table.

b. The resistances of the transformer windings and the coils in the signal generator are listed in table 6-3.

Table 6-3. Resistances of Transformer Windings and Coils

Transformer or coil	Terminals or leads	Resistance in ohms Model					
		Basic	A	B	C	D	
T1	Black to black-yellow 1 to 2	2.5					
	Black-red to black-green 3 to 4	2.5	1.6	1.4	1.6	1.4	
	Red to red 5 to 7	31.0	1.6	1.4	1.6	1.4	
	Slate to slate 10 to 11	0.17	30.5	39.0	30.5	39.0	
	Brown to brown 12 to 13	0.08	0.07	0.2	0.07	0.2	
	Green to green 14 to 15	0.17	0.04	0.08	0.04	0.08	
	Yellow to yellow 8 to 9	0.08	0.07	0.04	0.07	0.04	
	L1	0.5	0.04	0.065	0.04	0.065
	L2	0.93	0.2	0.5	0.2	0.5
L3	1.85	0.4	0.93	0.4	0.93	
L4	0.5	1.8	1.85	1.8	1.85	
L5	0.13	0.2	0.5	0.2	0.5	
L6	0.13	0.1	0.13	0.1	0.13	
L7	1 to 5	0.015	0.015	0.015	0.015	0.015	
	3 to 7	0.015	0.015	0.015	0.015	0.015	
	2 to 6	0.061	0.061	0.061	0.061	0.061	

Section IV. MAINTENANCE OF THE SIGNAL GENERATOR

6-10. General

Observe the following precautions carefully when servicing the signal generator:

- a. Replace components with the same value and tolerance and put in exactly the same position occupied by the original part,
- b. Do not disturb the settings of any adjustable component unless it has been definitely determined that the trouble is caused by an adjustment.

c. Be careful not to damage leads by pushing or pulling them out of the way.

d. Before a part is unsoldered, note the position of leads. If the part, such as the power transformer, has several connections, tag each lead.

e. Do not use a large soldering iron when soldering small resistors or ceramic capacitors. Overheating of the small parts may ruin or change values.

f. Do not allow drops of solder to fall into parts of the chassis because they may cause short circuits.

g. A carelessly soldered connection may create new faults. It is important to make well-soldered joints because a poorly soldered joint is one of the most difficult faults to find.

h. The following is a list of test equipment required for aligning and adjusting the signal generator:

Counter, Electronic Digital	
Readout, AN/USM-207	(NSN 6625-00-911-6368)
Oscilloscope, AN/USM-281	(NSN 6625-00-053-31 12)
Oscillator, Audio, AN/URM - 127	(NSN 6625-00-783-5965)
Voltmeter, Electronic, AN/USM-98	(NSN 6625-00-753-2115)

6-11. Replacement of Parts

The use of two printed circuits boards in the unlettered model of the signal generator necessitates special precautionary measures (*a* through *g* below) when servicing parts mounted on these boards. No special techniques are required for replacement of other parts in the unlettered model or in any of the lettered models of the signal generator.

a. A 25-watt soldering iron is required. A larger iron will loosen the bond between the phenolic board and the printed wiring and will cause excessive overheating of components.

b. To test or replace a component, unsolder one or both ends by applying the heat from the soldering iron to the connection on the bottom surface of the board. When the solder melts, remove the iron and, with a small wire brush, brush away the solder. More than one heating is required to completely remove the solder connections. However, this method must be used to prevent overheating of the circuit board.

c. When all solder is removed, insert a knife blade between the bent-over lead of the component and the board. Apply gentle pressure to straighten out the lead. Repeat this procedure for the other end of the component and lift the component away from the board.

d. When replacing the component, form and tin the leads before installing it onto the board. Bend the leads over on the bottom of the board so that the component will be held securely. Apply solder sparingly.

e. Tube sockets may be removed by applying the procedure described in *b* and *c* above.

f. Small breaks of 1/32-inch or less in the printed circuits are repaired by jumping the break with molten solder. When a break in the printed circuits is in excess of 1/32-inch, it shall be jumped with a piece of hookup wire.

g. When troubleshooting the printed circuit board, illuminate its printed side with a 25-watt lamp. This will permit the wiring to be seen from the component side of the board and greatly simplify circuit tracing.

6-12. Power Supply Adjustment

Proper operation of the signal generator depends on the correct functioning of the power supply circuit. Variations in the power supply will cause the multivibrator circuits to drift off calibration and cause erratic operation in the other circuits. Before attempting any other service work, check, and adjust if necessary, the power supply circuit for proper voltage as follows:

a. On signal generator, set power ON switch to off (down).

b. Connect positive terminal on dc voltmeter to chassis of signal generator and negative terminal to end terminal of R39 (terminal not connected to wiper arm).

c. Set controls of dc voltmeter to permit indication of - 200 volts dc.

d. On front panel of signal generator, set power switch to ON.

e. Observe indication on dc voltmeter. It should indicate - 200 volts dc. If not, proceed to step *f*.

f. Adjust potentiometer R95 (fig. 6-6, 6-16, or 6-17) until dc voltmeter indicates exactly - 200 volts dc .

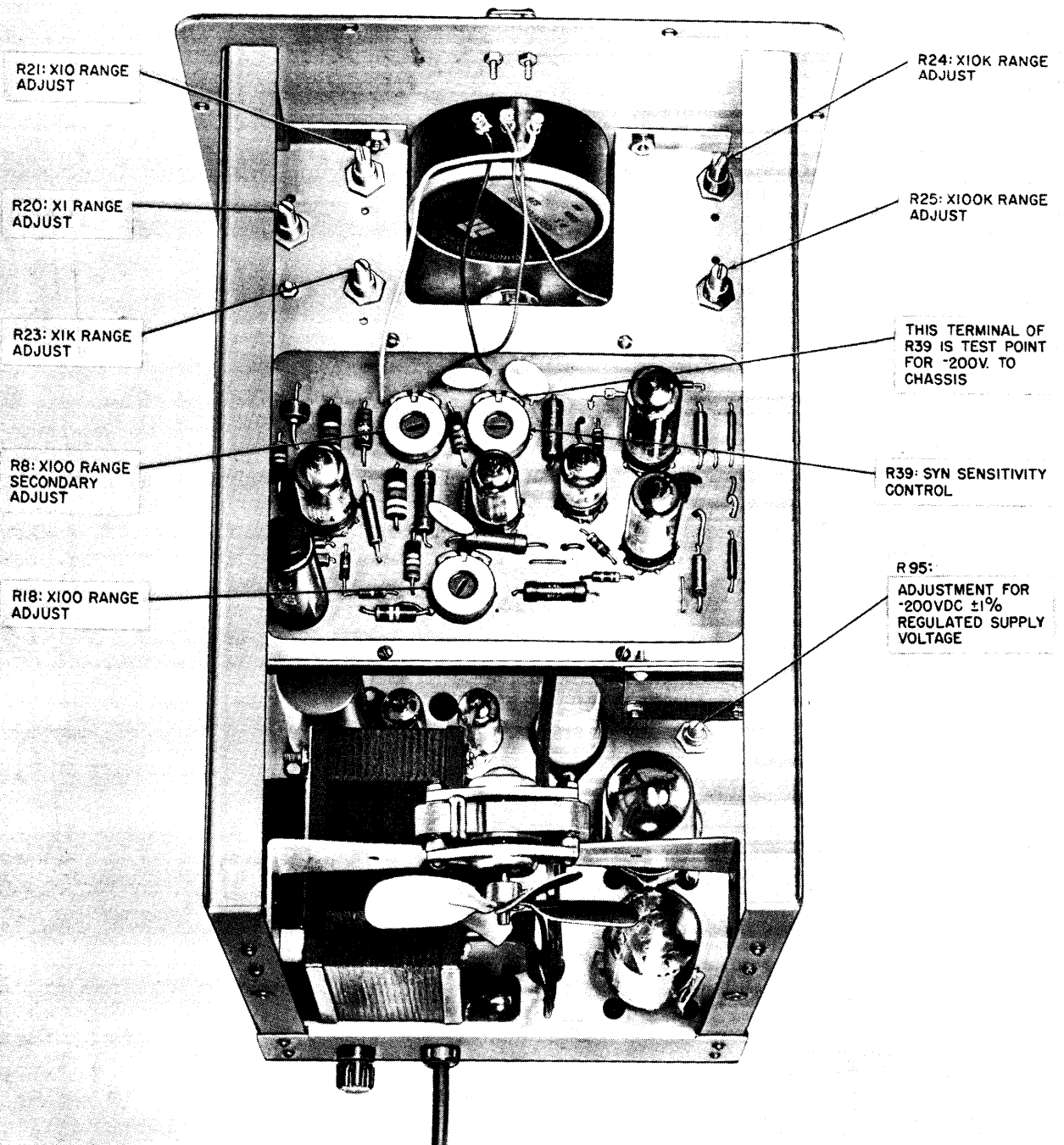

EL6625-258- 14-TM-32

Figure 6-16. Signal Generator SG-299/U, location of adjustment controls.

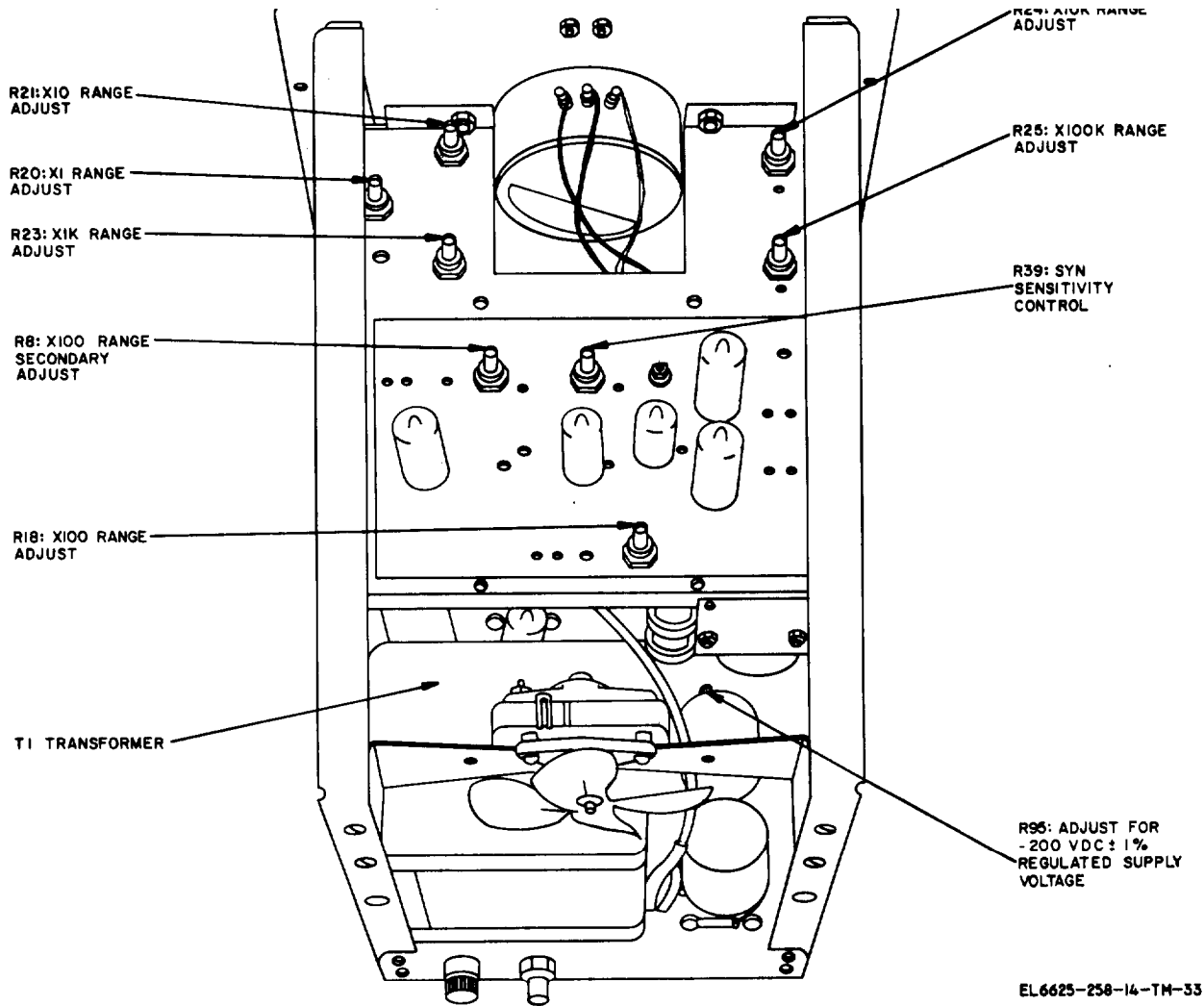

Figure 6-17. Signal Generator SG-299B/U, SG-299D/U, and SG-299E/U, location of adjustment controls.

6-13. Frequency Range Adjustment

The various frequency ranges available from the signal generator are determined by the time constant of an appropriate RC network switched into the multivibrator circuit by the setting of RANGE switch S 1. Each frequency range, except X100, is adjustable by means of a variable resistor in each RC network. For the X100 range, the proper multiplying factor is adjusted by variable resistor R18 in the cathode follower circuit of the multivibrator. For all frequency ranges, the frequency is varied from minimum to maximum by FREQUENCY control R9. Secondary or fine adjustment is provided by variable resistor R8 in series with FREQUENCY control R9.

NOTE

All frequency ranges are referenced to the "X100 range. Therefore, the X100 range must be adjusted first, using the procedures outlined in a below.

a. *Adjustment of X100 Range.* The X100 range is adjusted at the high frequency end of the range (1,000 Hz) using potentiometer R18, and at the low frequency end of the range (100 Hz) using potentiometer R8.

(1) Connect 75-ohm output of signal generator to FREQ A input of AN/USM-207 (counter) and 600-ohm output of signal generator to vertical INPUT A input of AN/USM-218A as shown in figure 6-18.

(2) On signal generator, set controls as follows:

<i>Control</i>	<i>Position</i>
Power ON switch.	off (down)
RANGE switch.	X100
75-ohm ATTEN "switch.	0 DB
OUTPUT AMPLITUDE-	
75-ohm control	7 (10 for unlettered model)
OUTPUT AMPLITUDE-	
600-ohm control	60 (10 for unlettered model)
SYMMETRY CONTROL	Midposition (white mark pointing up)

(3) operate counter for measurement and indication of frequency.

(4) On signal generator, set power ON switch to ON.

(5) Allow equipment to warm up for approximately 1 hour before proceeding with this adjustment.

(6) Set signal generator FREQUENCY control to 10.

(7) Adjust SYMMETRY control for a perfectly symmetrical pattern on oscilloscope, as shown in A, figure 6-19. (A nonsymmetrical waveform is shown in B, fig. 6-19.)

(8) Adjust X100 range adjust potentiometer R18 (fig. 6-4, 6-16, or 6-17) until frequency indication on counter is 1,000 Hz.

(9) On signal generator, set FREQUENCY control to 1.

(10) Adjust SYMMETRY control for **sym.** metrical pattern as observed on oscilloscope.

(11) Adjust X100 range secondary adjust potentiometer R8 until frequency indication on counter is 100 Hz.

(12) Repeat steps (6) through (11) until counter frequency indication is correct at both end settings of FREQUENCY control.

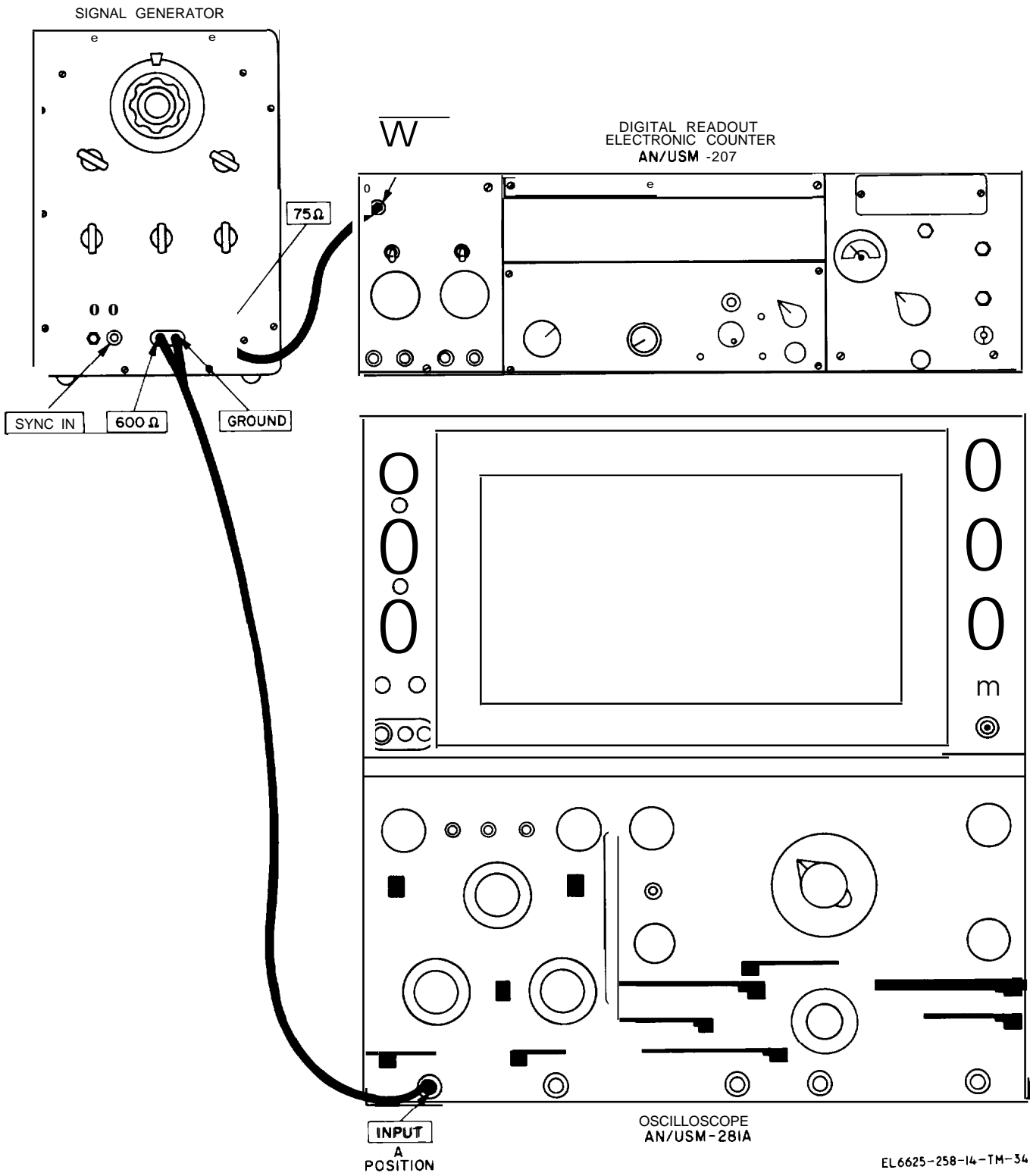

EL 6625-258-14-TM-34

Figure 6-18. Frequency adjustment test setup.

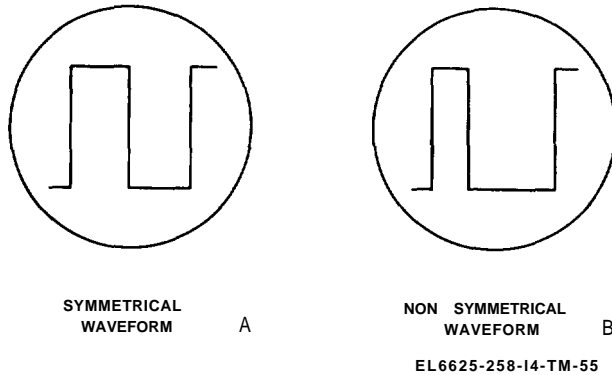

Figure 6-19. Symmetrical and nonsymmetrical waveforms.

b. Adjustment of X1K, X1K X10K, and X100K Ranges. Procedures described in a above must be performed before proceeding as follows:

(1) Use the same test setup (fig. 6-18) for these measurements.

(2) On signal generator, set **FREQUENCY** to 10.

(3) Adjust **SYMMETRY** control for symmetrical pattern on oscilloscope, as shown in A, figure 6-19.

(4) Set **RANGE** switch, in sequence shown, to settings given below, and, if necessary, adjust corresponding potentiometer (R23, R24, or R25—fig. 6-4, 6-16, or 6-17) to obtain proper frequency reading on counter:

Set RANGE switch to:	Adjust	Adjust for counter frequency reading of (Khz)
X1J	R23	10
X10K ∴	R24	100
X100K	R25	1000

c. Adjustment of X1 and X10 Ranges.

(1) Use test setup of figure 6-18 and operate counter for measurement and indication of period of signal generator output waveform.

(2) On signal generator, set **FREQUENCY** control to 10.

(3) Adjust **SYMMETRY** control for symmetrical pattern on oscilloscope, as shown in A, figure 6-19.

(4) Set **RANGE** switch, in sequence shown, to settings given below, and if necessary, adjust corresponding potentiometer (R20 or R21—fig. 6-4, 6-16, or 6-17) obtain proper 1-cycle period reading on counter:

Set RANGE switch to:	Adjust	Adjust for counter period reading of (millisecond)
x 1	R20	100
X10	R21	10

6-14. External Synchronization Sensitivity Adjustment

NOTE

Frequency adjustment (above) should be made prior to this adjustment.

The sync trigger circuit must be adjusted to permit a minimum 3-volt peak-to-peak level of an external synchronizing signal to activate the sync trigger circuit. Sync sensitivity potentiometer R39 (fig. 6-4, 6-16- or 6-17) is used to make this adjustment.

a. On signal generator, set power ON switch to off (down), **FREQUENCY** control to 10, and **RANGE** switch to X100.

b. Connect audio oscillator and counter test equipment to signal generator as shown in fig. 6-20.

c. On signal generator, set power ON switch to ON and allow signal generator to warm up for approximately 30 minutes.

d. Adjust AN/URM-127 to provide a sine wave output at a frequency of 1,000 Hz and an amplitude of 3.0 volts peak (2.2 volts rms).

e. On signal generator, set **FREQUENCY** to 9.8 or 7 depending upon model.

f. Adjust, if necessary, potentiometer R39 (fig. 6-4, 6-16, or 6-17) until counter indicates 1,000 Hz.

6-15. Power Transformer Conversion

In all models of the signal generator, conversion from 115-volt. 60-Hz to 230-volt. 60-Hz operation is accomplished by changing the primary windings of the power transformer from a parallel to a series arrangement. Conversion procedures differ between the unlettered model and the lettered models mainly in the type of identification given to the leads of the power transformer primary windings.

a. *Unlettered Model.* The unlettered model of the signal generator may be converted for 230-volt, 60-Hz operation as follows (fig. FO-4):

(1) Remove jumper wire that connects black lead of power transformer to black-green lead of power transformer.

(2) Remove jumper wire that connects black-yellow lead of power transformer to black-red lead of power transformer.

(3) Connect new jumper wire from black-yellow lead to the black-green lead.

(5) The fan shall remain connected between black and black-yellow leads is power transformer.

b. *A Model (Order No. 39108 -PP-58).* The A model of the signal generator, under Order No. 3Y108-PP-58, may be converted for 230-volt, 60-Hz operation as follows (fig. FO-5):

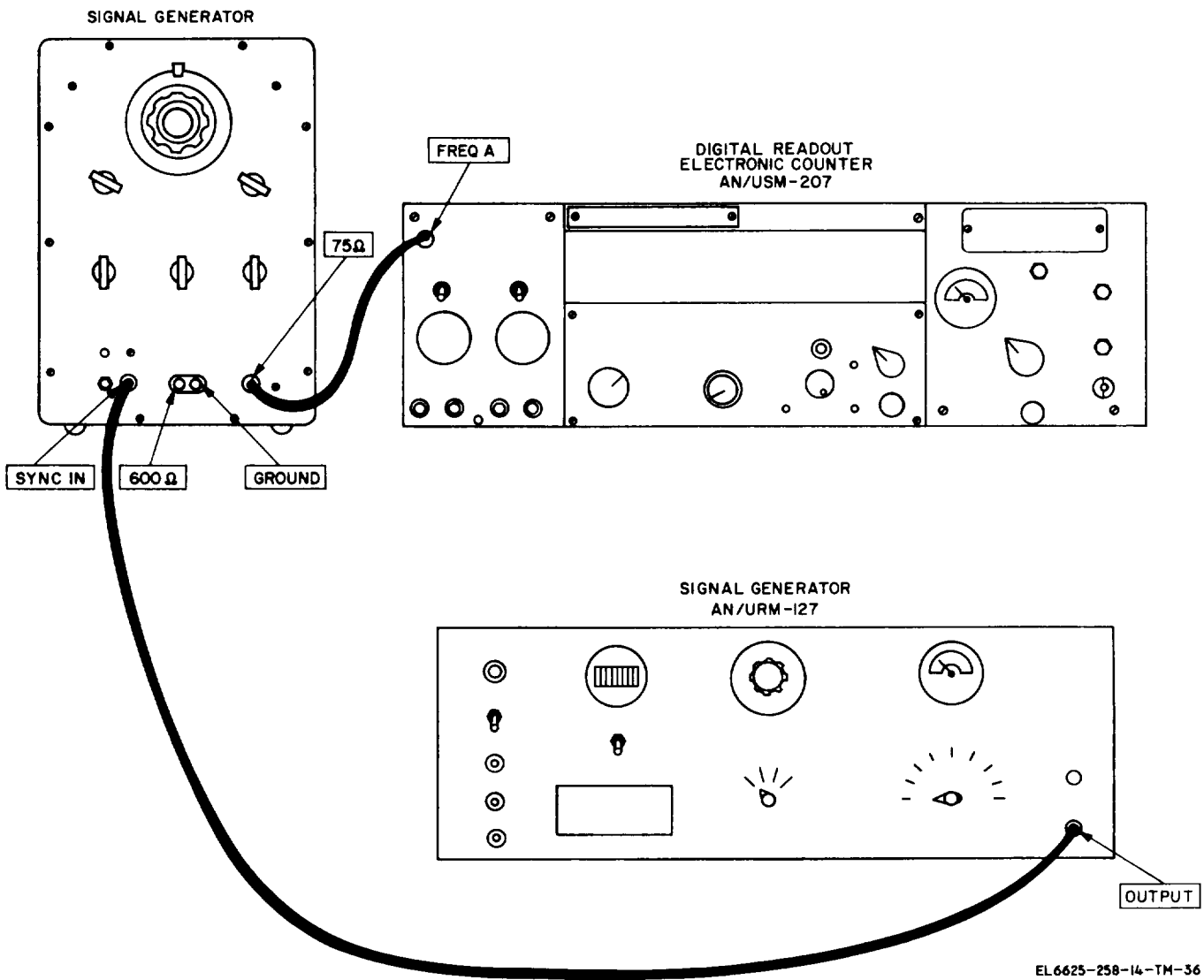

EL 6625-258-14-TM-36

Figure 6-20. External synchronization sensitivity test setup

- (1) Locate lead that is connected from S3 to terminal 2 of power transformer T1.
- (2) Unsolder this lead at terminal 2 of T1.
- (3) Solder this lead from S3 to terminal 4 of T1.
- (4) Solder jumper wire between terminals 2 and 3 of T1.
- (5) The fan shall remain connected between terminals 1 and 2 of T1.

c. *All Remaining Lettered Models.* The other lettered models of the signal generator, including the A model of Order No. 4502 -PP-60, may be converted for 230-volt, 60-Hz operation as follows (fig. FO-6):

- (1) Unsolder jumper wire connected between terminals 1 and 3 of power transformer T1.
- (2) Unsolder jumper wire connected between terminals 2 and 4 of T1.
- (3) Solder new jumper wire between ter-

minals 2 and 3 of T1.

- (4) The fan shall remain connected across terminals 1 and 2 of T1.

6-16. Conversion for 115-volt, 60-Hz Operation

If 115-volt, 60-Hz operation is desired and the signal generator has been wired for 230-volt, 60-Hz operation, conversion may be accomplished as follows:

a. *Unlettered Model.*

- (1) Unsolder the jumper wire from the black-yellow lead of the primary transformer primary windings to the black-green lead.
- (2) Connect a new jumper wire from the black-yellow lead to the black-red lead of the power transformer.
- (3) Connect a jumper wire from the black lead to the black-green lead.

(4) The fan shall remain connected between the black and black -yellow leads.

b. A Model (Order No. 39108 -PP-58).

(1) Unsolder jumper wire between terminals 2 and 3 of T1.

(2) Unsolder lead connecting S3 to terminal 4 of T1 at terminal 4 only,

(3) Solder the same lead (from S3) to terminal 2 of T1.

(4) The fan shall remain connected between terminals 1 and 2 of T1.

c. A 11 Remaining Lettered Models. Conversion

to 115-volt, 60-Hz operation for the other lettered models, including the A model of Order No. 4502-PP -60, is accomplished as follows:

(1) Unsolder the jumper wire between terminals 2 and 3 of T1.

(2) Solder a jumper wire between terminals 2 and 4 of T1.

(3) Solder a jumper wire between terminals 1 and 3 of T1.

(4) The fan shall remain connected across terminals 1 and 2 of T1.

Section V. GENERAL SUPPORT TESTING PROCEDURES

6-17. General

a. Testing procedures are prepared for use by electronics field maintenance shops and electronics service organizations responsible for general support of repaired electronic equipment to determine the acceptability of repaired equipment. These procedures set forth specific requirements that repaired equipment must meet before being returned to the using organization. These procedures may also be used as a guide for testing equipment that has been repaired at direct support maintenance if the proper tools and test equipment are available.

b. Comply with the instructions preceding each table before proceeding to the table. Perform each step in sequence. Do not vary the sequence. For each step, perform all the actions required in the *Test equipment* and *Equipment under test* columns. Perform each specific procedure and verify the result against the information con-

tained in the *Performance standard* column.

6-18. Modification Work Orders

There were no modification work orders (MWO) applicable to the signal generator at the time standards were set. A listing of current modification work orders will be found in DA Pam 310-7.

6-19. Test Equipment Required.

All test equipment required to perform the testing procedures given in this section are listed in Appendix C, Maintenance Allocation,

6-20. Physical Tests and Inspections

a. *Test Equipment and Materials.* No test equipment or materials are required.

b. *Test Connections and Conditions.*

(1) No connections necessary.

(2) Remove signal generator chassis from its case.

c. *Procedure.* Refer to table 6-4 for procedures.

Table 6-4. Physical Tests and Inspections

Step no.	Control settings		Test procedure	Performance standard
	Test equipment	Equipment under test		
1	None	Controls may be in any position.	<p>a. Inspect case and chassis for damage, missing parts, and condition of paint.</p> <p style="text-align: center;">NOTE</p> <p>Touchup painting is recommended instead of refinishing whenever practical; screw heads, binding post, receptacles, and other plated parts should not be painted or polished with abrasives.</p> <p>b. Inspect all controls and mechanical assemblies for loose or missing screws, bolts, and nuts.</p> <p>c. Inspect all connectors, sockets, and receptacles, fuse holders, and dials for looseness, damage, or missing parts.</p>	<p>a. No damage evident or parts missing. External surfaces intended to be painted must not show bare metal (primed). Panel lettering must be legible.</p> <p>b. Screws, bolts, and nuts must be tight. None missing.</p> <p>c. No loose parts or damage. No missing parts.</p>
2	None	Controls may be in any position.	<p>a. Rotate all panel controls throughout their limits of travel.</p> <p>b. Inspect dial stops for damage or bending and for proper operation.</p> <p>c. Operate all switches.</p>	<p>a. Controls must rotate freely without binding or excessive looseness.</p> <p>b. Stops operate properly without evidence of damage.</p> <p>c. Switches must operate properly.</p>

SIGNAL GENERATOR SG-299/U

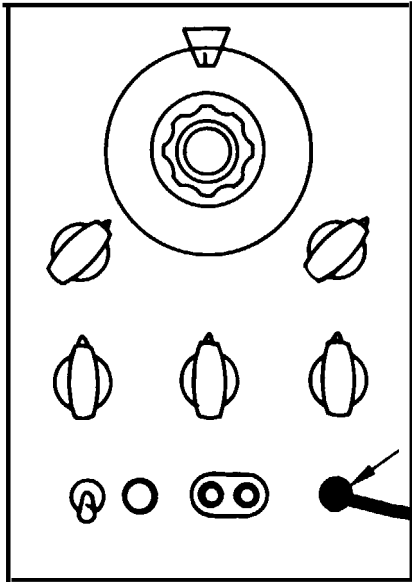

75 Ω

OSCILLOSCOPE AN/USM-281A

A
INPUT

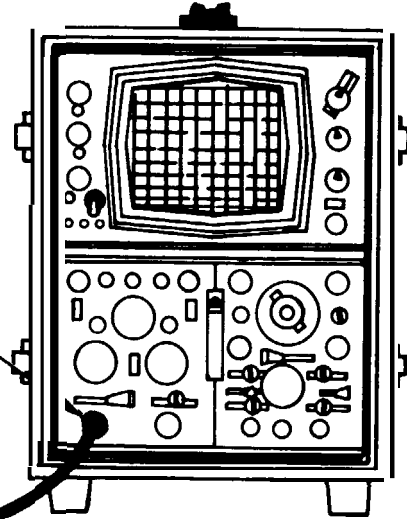

EL 6 6 2 5 - 2 5 8 - 1 4 - T M - 4 2

Figure 6-21. Symmetry test setup.

6-21. Symmetry Test

- a. *Test Equipment.* Oscilloscope AN/USM-281.
- b. *Test Connections and Conditions.* Connect 75 Ω output coaxial connector of signal generator

under test to position A input connector of oscilloscope. Allow warmup period of approximately 30 minutes for all equipment.

- c. *Procedure.* Refer to table 6-5 for procedures.

Table 6-5. Symmetry Test

Step no.	Control settings		Test procedure	Performance standard
	Test equipment	Equipment under test		
1	Oscilloscope SWEEP MODE switch: Normal HORIZONTAL-DISPLAY switch: INT. TIME/CM switch: 20 MSEC VERTICAL DISPLAY switch: A	Frequency control: 10 75 Ω ATTEN switch: 0 DB RANGE switch: X100 OUTPUT AMPLITUDE - 75 Ω control: 7 (10 for unlettered model) OUTPUT AMPLITUDE - 600 Ω control: 60 (10 for unlettered model)	After warmup period, adjust SYMMETRY control of signal generator until symmetrical (equal half periods) waveform is obtained on oscilloscope, as shown in A, figure 6-2.	Position of SYMMETRY control after symmetrical waveform has been displayed shall be between +30° and -30° of its midposition (white dot or arrow pointing up).
2	Same as step 1.	Same as step 1.	Rotate SYMMETRY control over its full range and note any change in frequency of output signal.	Frequency of output signal shall be between 990 and 1,010 Hz throughout range of SYMMETRY control.

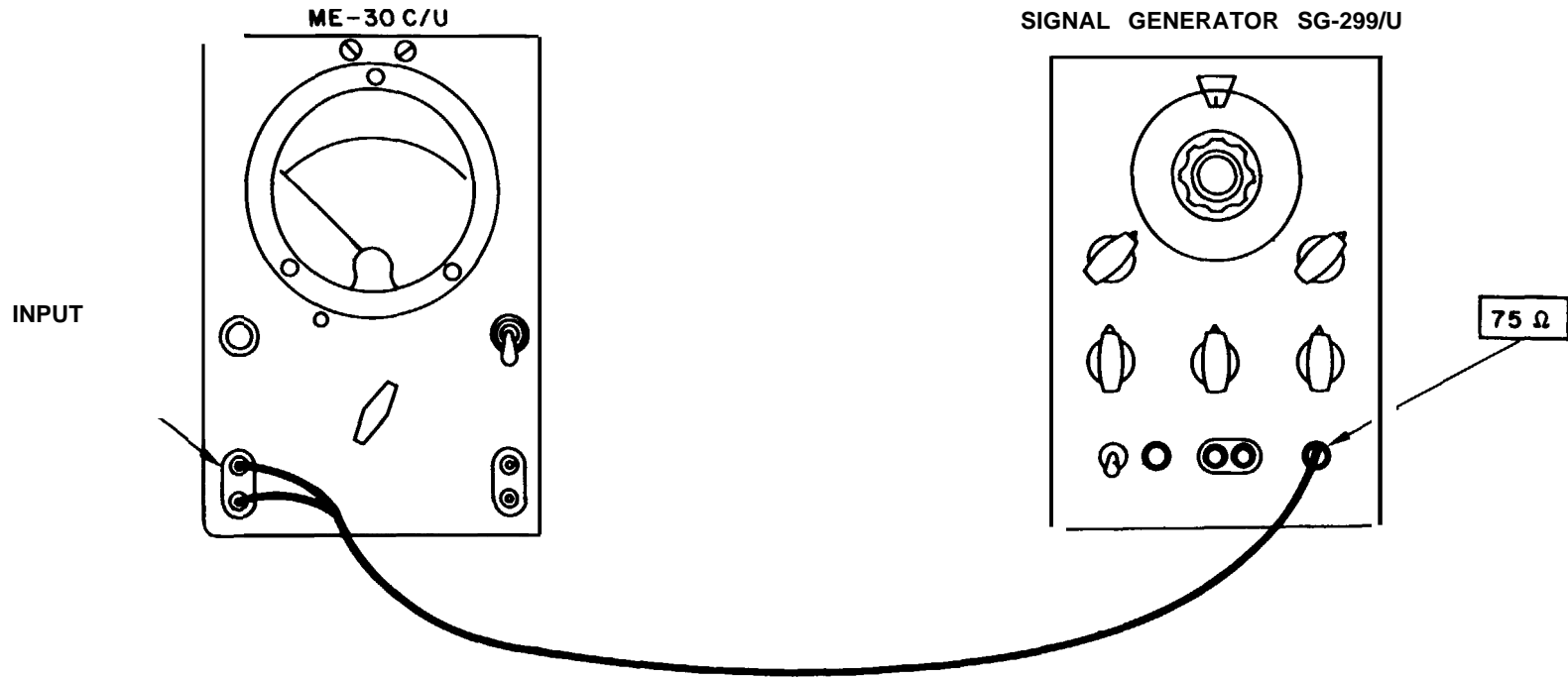

EL6625-258-14-TM-43

Figure 6-22. Low impedance output voltage test setup.

6-22. Low Impedance Output Voltage Test

a. Test *Equipment*. Voltmeter, Electronic ME-30(*) /U (voltmeter).

b. *Test Connections and Conditions*. Connect

the 75 Ω output coaxial connector of the signal generator under test to the INPUT terminals of the voltmeter.

c. *Procedure*. Refer to table 6-6 for procedures.

Table 6-6. Low Impedance Output Voltage Test

Step no.	Control settings		Test procedure	Performance standard
	Test equipment	Equipment under test		
1	Voltmeter RANGE switch: 10 volts	75 Ω ATTEN switch: 0 DB OUTPUT AMPLI- TUDE - 75 Ω control: 7 (10 for unlettered model) RANGE switch: X100 FREQUENCY control: 10	Adjust SYMMETRY control of signal generator until maximum deflection is obtained on voltmeter.	Voltmeter indication shall be 3.5 volts minimum.
2	Same as step 1.	Same as step 1.	Set OUTPUT AMPLITUDE-75 Ω control to 0 and observe deflection on voltmeter.	Voltmeter indication shall be 0 volt.

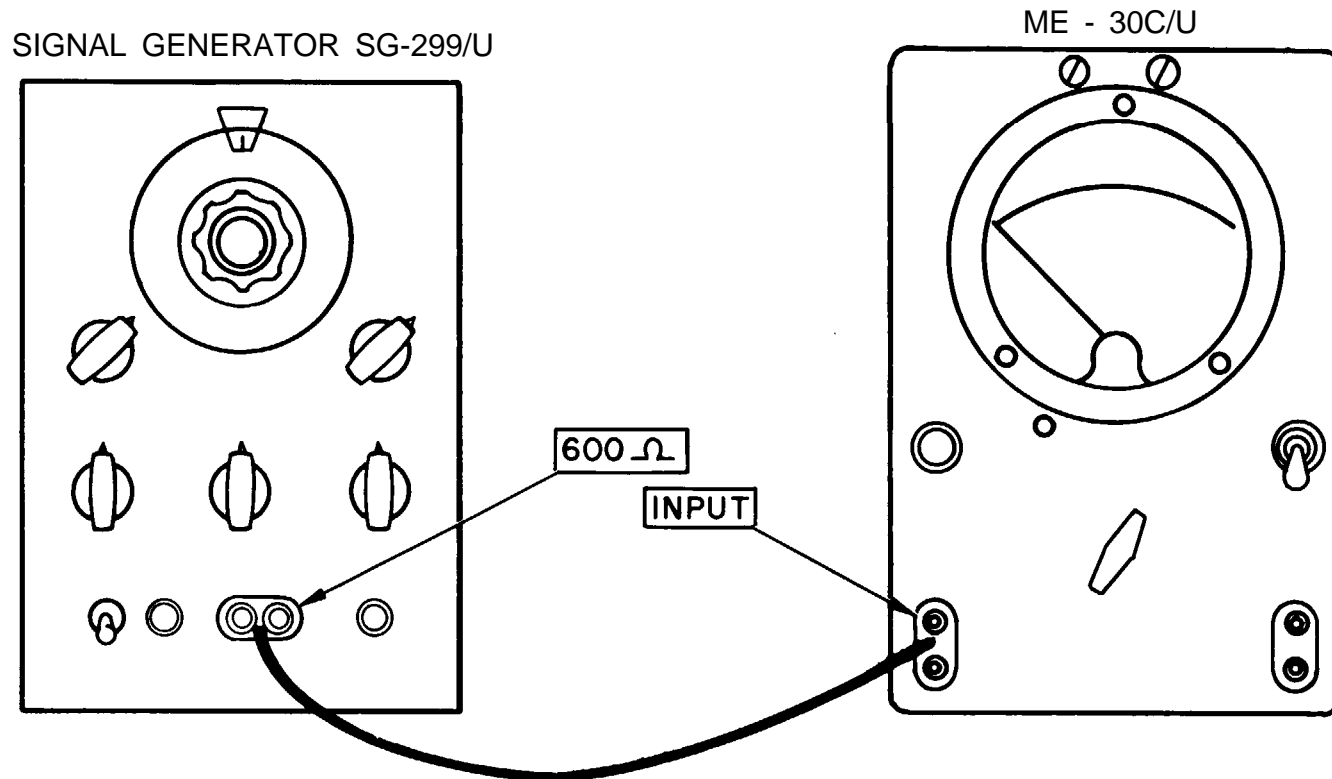

EL6625-258-14-TM-44

Figure 6-23. High impedance output voltage test setup.

6-23. High Impedance Output Voltage Test

a. *Test Equipment.* Voltmeter, Electronic ME-30(*)/U (voltmeter).

b. *Test Connections and Conditions.* Connect

600 Ω terminals of signal generator under test to the INPUT terminal of voltmeter.

c. *Procedure.* Refer to table 6-7 for procedures.

Table 6-7. High Impedance Output Voltage Test

Step no.	Control settings		Test procedure	Performance standard
	Test equipment	Equipment under test		
1	Voltmeter RANGE switch: 100 volts	75 Ω ATTEN switch: 0 DB OUTPUT AMPLITUDE - 600 Ω control: 7 (10 for unlettered model) RANGE switch: X100 FREQUENCY control: 10	Adjust SYMMETRY control of signal generator until maximum deflection is obtained on voltmeter.	Voltmeter indication shall be 27.5 volts minimum.
2	Same as step 1.	Same as step 1.	Set OUTPUT AMPLITUDE - 600 Ω control to 0 and observe deflection on voltmeter.	Voltmeter indication shall be 0 volt.

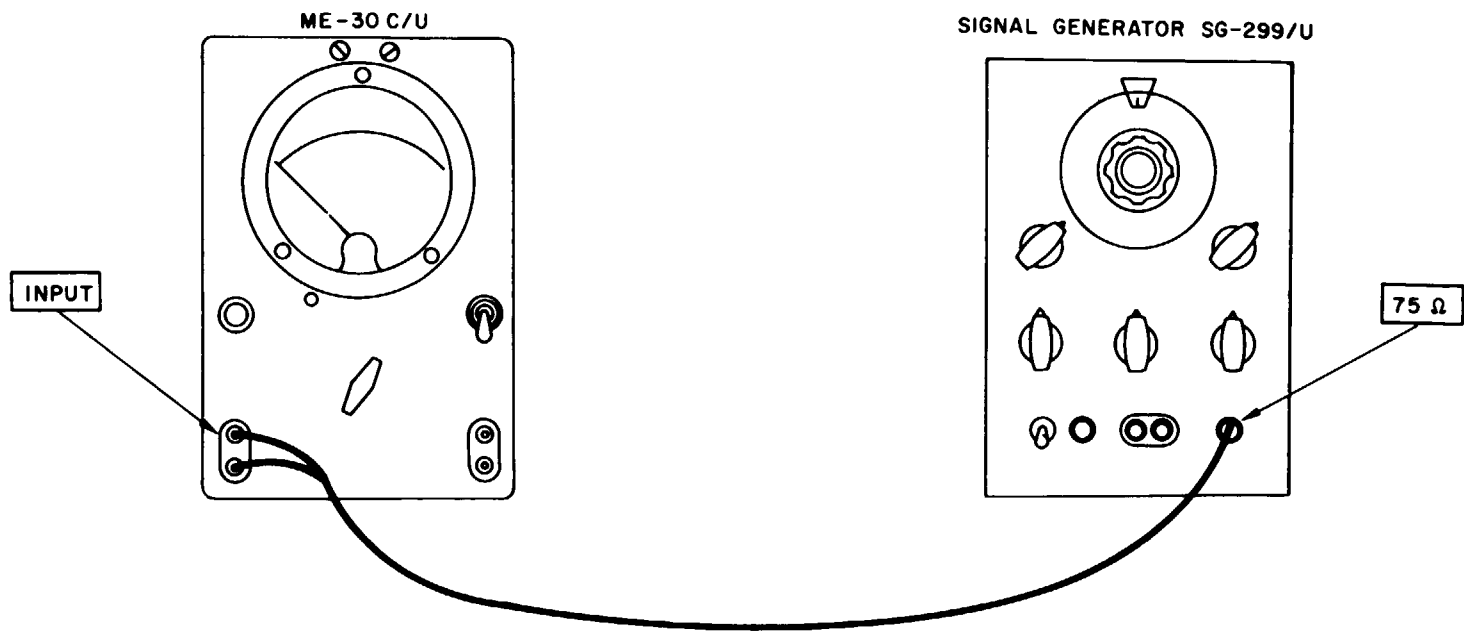

Figure 6-24. Low impedance output attenuation test setup.

EL6625-258-14-TM-43

6-24. Low Impedance Output Attenuation Test

a. *Test Equipment.* Voltmeter, Electronic ME-30(*) /U (voltmeter).

b. *Test Connections and Conditions.* Connect

75 Ω output coaxial connector of signal generator under test to INPUT terminals of voltmeter.

c. *Procedure.* Refer to table 6-8 for procedures.

Table 6-8. Low Impedance Output Attenuation Test

Step no.	Control settings		Test procedure	Performance standard
	Test equipment	Equipment under test		
1	Voltmeter RANGE switch: +20 DB (10 volts)	75 Ω ATTEN switch: 0 DB OUTPUT AMPLITUDE - 75 Ω control: 7 (10 for unlettered model) RANGE switch: X100 FREQUENCY control: 10	Adjust SYMMETRY control of signal generator until maximum deflection is obtained on voltmeter. Record DB Scale indication for reference.	Voltmeter indication on VOLT scale shall be 5 volts minimum.
2	RANGE switch: 0 DB (1 volt)	75 Ω ATTEN switch: 20 DB	Note indication on DB Scale of voltmeter.	Indication shall be within ± 1 dB of reading noted in step 1.
3	RANGE switch: -20 DB (1 volt)	75 Ω ATTEN switch: 40 DB	Note DB Scale indication of voltmeter.	Indication shall be within ± 1 dB of reading noted in step 1.
4	RANGE switch: -40 DB (.01 volt)	75 Ω ATTEN switch: 60 DB	Note DB Scale indication of voltmeter.	Indication shall be within ± 1 dB of reading noted in step 1.

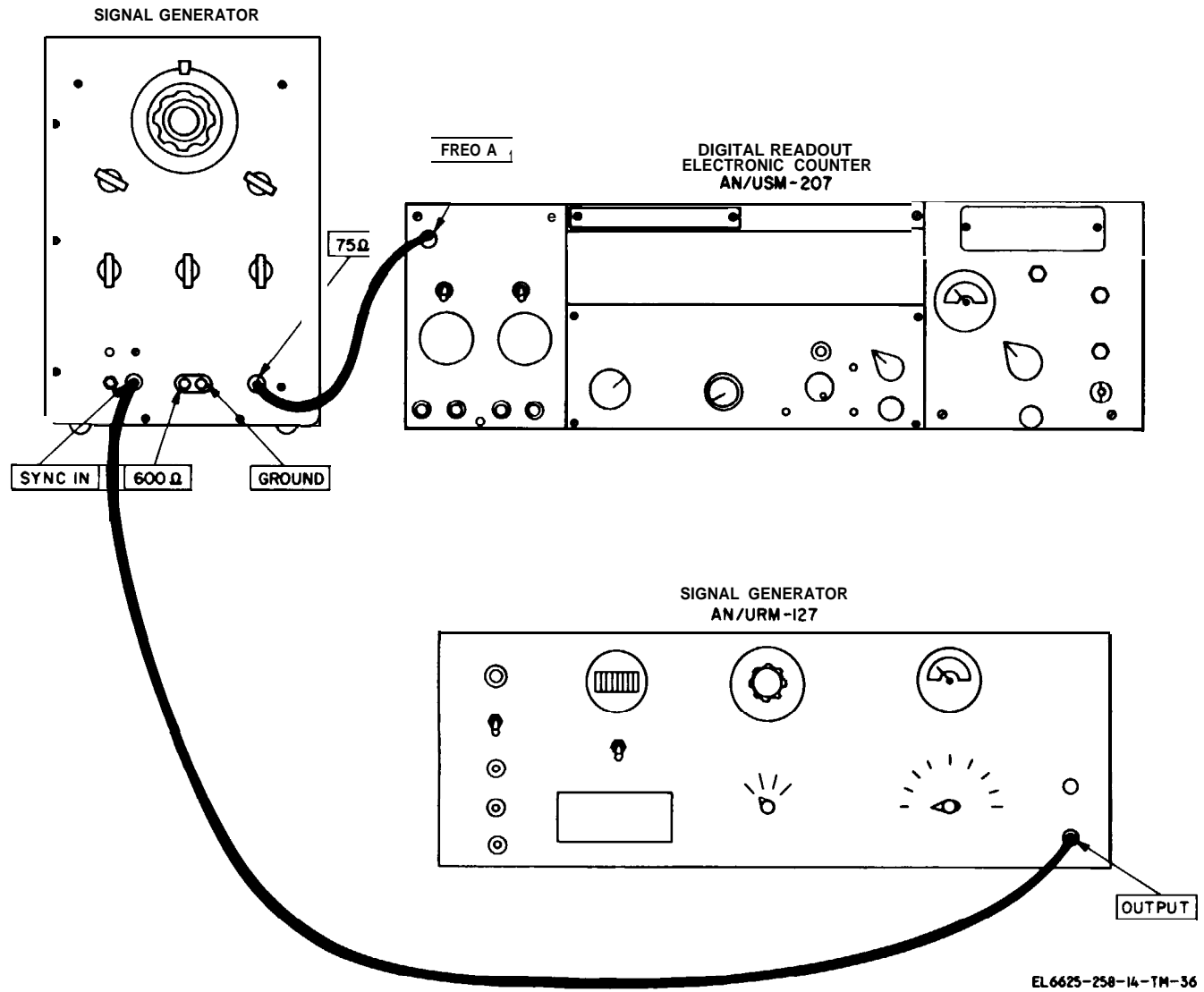

Figure 6-25. External synchronization test setup.

6-25. External Synchronization Test

a. Test Equipment.

(1) Signal Generator AN/URM-127 (audio Oscillator) .

(2) Digital Readout, Electronic Counter AN /USM-207 (counter).

b. Test Connections and Conditions. Connect

equipment as shown in figure 6-25. Operate audio oscillator to provide 1,000-Hz, 3.5-volt rms signal at its OUTPUT connector. Allow warmup period of 30 minutes for all equipment.

c. Procedure. Refer to table 6-9 for correct procedures.

Table 6-9. External Synchronization

Step no.	Control settings		Test procedure	Performance standard
	Test equipment	Equipment under test		
1	Counter FUNC- TION switch: FREQ GATE TIME (sec -1) Switch: 10 ⁴	FREQUENCY control: 10 RANGE switch: X100 75 Ω ATTEN switch: 0 DB OUTPUT AMPLI- TUDE - 75 Ω control: 7 (10 for unlettered model) SYMMETRY control: midposition	Note counter and record indication for reference.	Counter indication should be between 900 and 1,100 Hz.
2	Same as step 1.	FREQUENCY control: 8.5	Note indication on counter.	Counter indication shall be the same as recorded in step 1.

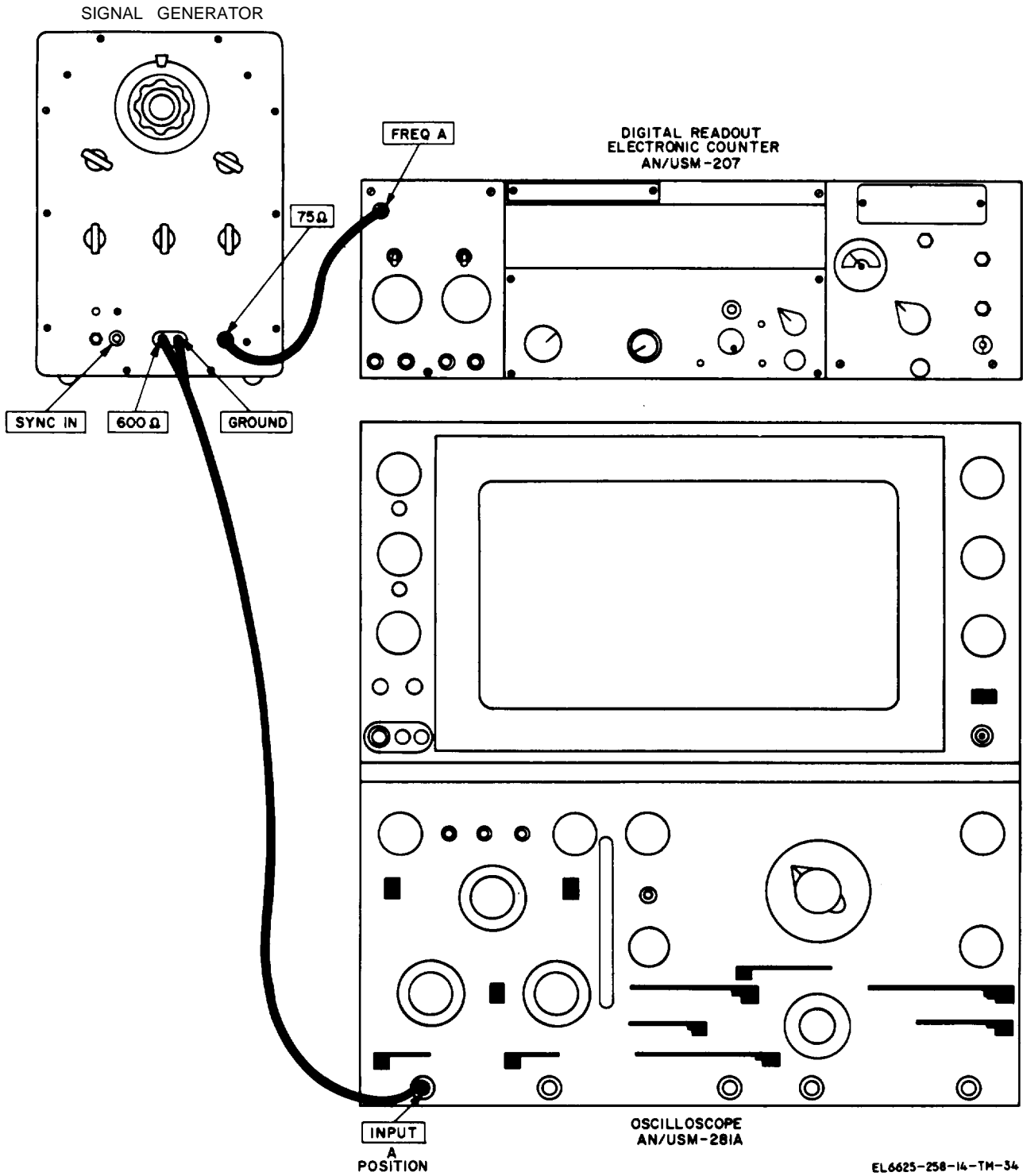

Figure 6-26. Frequency range tracking test setup.

6-26, Frequency Range Tracking Test

a. *Test Equipment.*

(1) Digital Readout, Electronic Counter AN/USM-207 (counter).

(2) Oscilloscope AN/USM-281(*).

b. *Test Connections and Conditions.* Connect

equipment as shown in figure 6-26. Allow warmup period of approximately 30 minutes for all equipment.

c. *Procedures.* Refer to table 6-10 for procedures.

Table 6-10. Frequency Range Tracking Test

Step no.	Control settings		Test procedure	Performance standard
	Test equipment	Equipment under test		
1	Oscilloscope SWEEP MODE switch: NORMAL HORIZON- TAL- DISPLAY switch: INT SWEEP TIME switch: 20 MSEC Vertical DISPLAY switch: A Counter FUNC- TION switch: FREQ ATE TIME (sec -1) Switch: 10 ⁴	FREQUENCY CONTROL: 10 RANGE switch: X100 75 Ω ATTEN switch: 0 DB OUTP UT AMPLI- TUDE -75 Ω control: (10 for unlettered model) UT PUT AMPLI - TUDE -600 Ω control: 70 (10 for unlettered model)	Adjust SYMMETRY control of signal generator under test until symmetrical waveform, as shown in figure 6-19, is displayed on oscilloscope. Note indication on counter.	Indication on counter shall be between 900 and 1,100 Hz.
2	Same as step 1.	FREQUENCY control: 1	Note indication on counter.	Indication on counter shall be between 90 and 110 Hz. Indication on counter shall be between 9 and 11 kHz.
3	Same as step 1.	FREQUENCY control: 10 RANGE switch: X1K	Note indication on counter.	
4	Same as step 1.	RANGE switch: X10K	Note indication on counter.	Indication on counter shall be between 90 and 110 kHz. Indication on counter shall be Between 900 and 1,100kHz.
s	Same as step 1.	RANGE switch: X100K	Note indication on counter.	

Table 6-10. Frequency Range Test-Continued

Step no.	Control settings		Test procedure	Performance standard
	Test equipment	Equipment under test		
6	Counter FUNC- TION switch: PERIOD BXN-1. Time base CLOCK FREQ (cps) switch: 10 ⁴	RANGE switch: X10	Note indication on counter.	Indication on counter shall be between 909 and 1,110 ms.
7	Same as step 6.	RANGE switch: X1	Note indication on counter.	Indication on counter shall be between 90 and 111 ms.

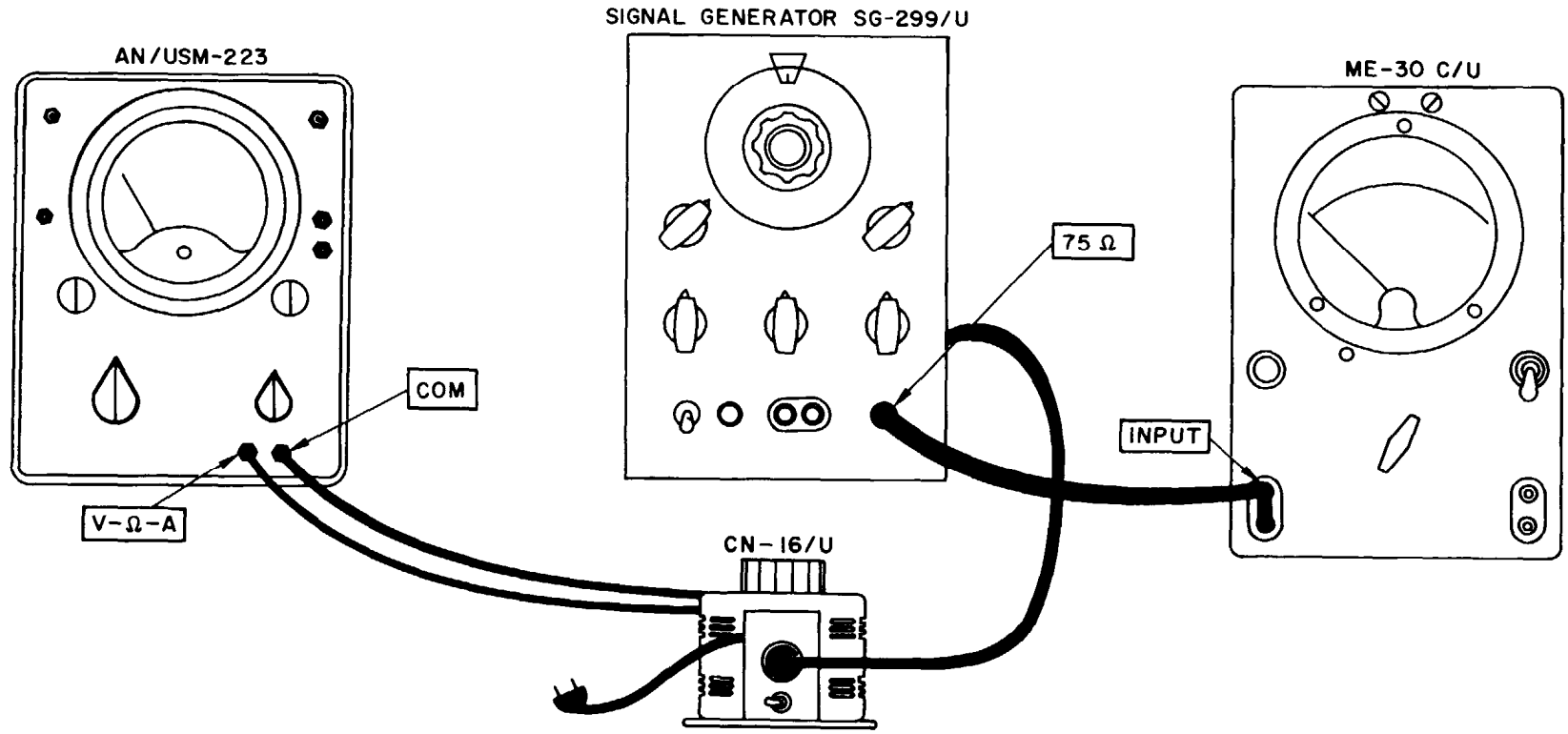

EL6625-258-14-TM-45

Figure 6-27. output amplitude, line voltage variation test setup.

6-27. Output Amplitude, Line Voltage Variation Test

a. Test Equipment.

(1) **Voltmeter**, Electronic M E 3 0 (*) / U (voltmeter).

(2) Multimeter AN/USM-223.

(3) Transformer, Variable Power, CN-16/U.

b. Test Connections and Conditions.

(1) Connect 75 Ω output coaxial connector of signal generator under test to INPUT terminals of voltmeter.

(2) Connect ac power source to input of

variable autotransformer and connect output of variable autotransformer to power input of signal generator. Allow approximately 30 minutes for warmup of signal generator.

(3) Connect multimeter, set for ac measurement, 300-volt range, across output of variable autotransformer.

(4) Adjust variable autotransformer control until 115 volts ac is indicated on multimeter.

c. Procedures. Refer to table 6-11 for procedures.

Table 6-11. Output Amplitude, Line Voltage Variation Test

Step no.	Control settings		Test procedure	Performance standard
	Test equipment	Equipment under test		
1	Voltmeter RANGE switch: 10 volts	FREQUENCY control: 10 RANGE switch: X100 75 Ω ATTEN switch: 0 DB	Adjust OUTPUT AMPLITUDE—75 Ω control of signal generator until 5.0 volts peak-to-peak (3.5 volts rms) is indicated on voltmeter. Adjust variable autotransformer control until 105 volts ac is indicated on multimeter.	Voltmeter indication shall be between 3.43 and 3.57 volts.
2	Same as step 1.	Same as step 1.	Adjust variable autotransformer control until 125 volts ac is indicated on multimeter.	Voltmeter indication shall be between 3.43 and 3.57 volts.

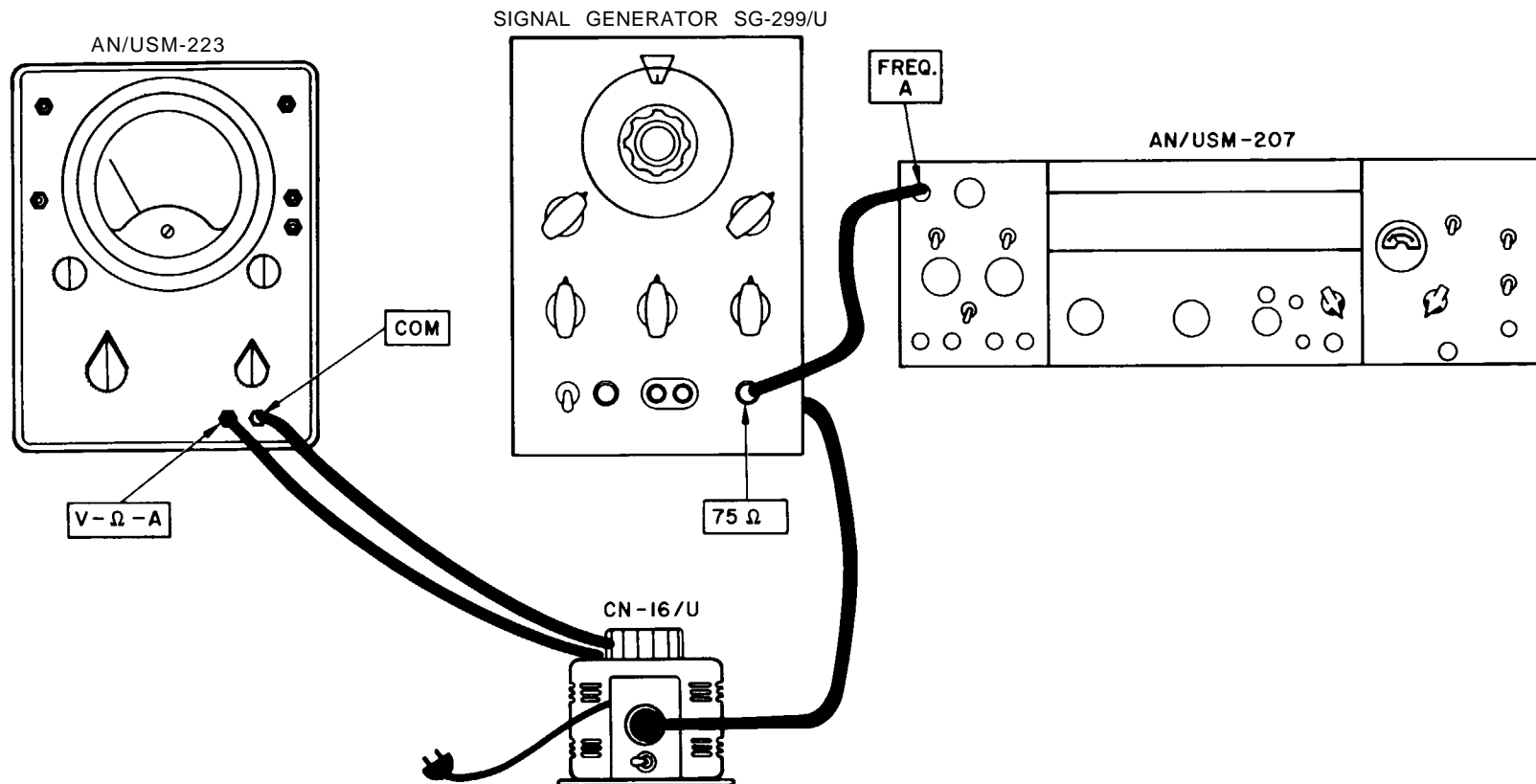

EL6625-258-14-TM-46

Figure 6-28. Output frequency, line voltage variation test setup.

6-28. Output Frequency, Line Voltage Variation Test

a. Test Equipment.

- (1) Digital Readout, Electronic Counter AN /U SM-207 (counter).
- (2) Multimeter AN/USM-223.
- (3) Transformer, Variable Power, CN-16/U.

b. Test Connections and Conditions.

- (1) Connect 75 output coaxial connector of signal generator under test to **FREQ A** coaxial connector of counter.
- (2) Connect ac power source to input of

variable autotransformer and connect output of variable autotransformer to power input of signal generator. Allow approximately 30 minutes for warmup of all units.

(3) Connect multimeter, set for ac measurement, 300-volt range, across output of variable autotransformer.

(4) Adjust variable autotransformer control unit **115 volts ac is indicated on multimeter.**

c. Procedures. Refer to table 6-12 for procedures.

Table 6-12. Output Frequency, Line Voltage Variation Test

Step no.	Control settings		Test procedure	Performance standard
	Test equipment	Equipment under test		
1	Counter FUNC- TION switch: FREQ GATE TIME (sec -1) Switch: 10*	75 Ω ATTEN switch: 0 DB RANGE switch: X100 OUTPUT AMPLI- TUDE - 75 Ω control: 7 (10 for unlettered model)	Adjust FREQUENCY control of signal generator until 1,000 Hz is indicated on counter. Adjust variable autotransformer control until 105 volts ac is indicated on multimeter.	Counter indication shall be between 980 and 1,020 Hz.
2	Same as step 1.	Same as step 1.	Adjust variable autotransformer control until 125 volts ac is indicated on multimeter.	Counter indication shall be between 980 and 1,020 Hz.

6-29. Test Data Summary

Prepare a checklist from the tests that have been performed, to be used as a check against findings in future tests. Personnel may find it convenient to arrange the checklist in a manner similar to that shown below.

1. Symmetry Test

- a.* Symmetrical **SYMMETRY** control waveform at midposition §30°.
- b.* **SYMMETRY** Between 990 and control rotated 1,010 Hz. through its full range.

2. Low Impedance Output Voltage Test

- a.* **SYMMETRY** Not less than 5 volts. control positioned for maximum output amplitude.
- b.* **OUTPUT AM- O volt.**
PLITUDE-75
control at O.

3. High Impedance Output Voltage Test

- a.* **SYMMETRY** Not less than 38 volts. control positioned for maximum output amplitude.
- b.* **OUTPUT AM- O Volt.**
PLITUDE-600 Ω
control at O.

4. Low Impedance output Attenuation Test

- a.* **SYMMETRY** Not less than 5 volts control positioned for (note DB indication). maximum output amplitude.
- b.* 75 ATTEN Within ± 1dB of switch at 20 DB and reading noted in *a.* RANGE
voltage meter switch at 0 DB.
- c.* 75 Ω ATTEN Within ± 1dB of switch at 40 DB and reading noted in *a.* RANGE
voltage meter switch at -20 DB.

d. 75 Ω ATTEN Within ± 1 dB of switch at 60 DB and reading noted in a. volt meter RANGE switch at - 40 DB.

5. External Synchronization Test

a. External sync: 1000 Between 900 and Hz; FREQUENCY 1,100 Hz (note indication). control at 10; RANGE switch at X100; OUTPUT AMPLITUDE-75 Ω control: 7 (10 for unlettered model); SYMMETRY control at midposition .

b. FREQUENCY Between 900 and control 8.5. 1,100 Hz.

6. Frequency Range Tracking Test

a. FREQUENCY Between 900 and control at 10; RANGE 1,100 Hz. switch at X100; OUTPUT AMPLITUDE-75 Ω control: 7 (10 for unlettered model); OUTPUT AMPLITUDE-600 Ω control: 7 (10 for unlettered model); SYMMETRY control set for symmetrical waveform.

b. FREQUENCY Between 90 and 110 control to 1 Hz.

c. FREQUENCY Between 9 and 11 kHz-control 10; RANGE z.

switch to X1K.

d. RANGE switch to X10K..... Between 90 and 110 kHz,

e. RANGE switch to X100K..... Between 900 and 1100 kHz.

f. RANGE switch to X10..... Between 909 and 1,110 ms.

g. RANGE switch to X1..... Between 90 111 ms.

7. Output Amplitude, Line Voltage Variation Test

a. Line voltage: 115 Reference volts ac OUTPUT AMPLITUDE-75 Ω control set for 5 volts peak-to-peak (3.5 volts rms) on voltmeter.

b. Line voltage: 105 Between 3.43 and 3.57 volts ac volts rms.

c. Line voltage: 125 Between 3.43 and 3.57 volts ac volts rms.

8. Output Frequency, Line Voltage Variation Test

a. Line voltage: 115 Reference volts ac Frequency set at 1,000 Hz,

b. Line voltage: 105 Between 980 and volts 1,020 Hz.

c. Line voltage: 125 Between 980 and volts ac 1,020 Hz.

APPENDIX A

REFERENCES

DA Pam 310-4	Index of Technical Manuals, Technical Bulletins, Supply Manuals (types 7,8, and 9), Supply Bulletins, and Lubrication Orders.
DA Pam 310-7	US Army Equipment Index of Modification Work Orders.
SB 38-100	Preservation, Packaging, Packing and Marking Materials, Supplies, and Equipment Used by the Army.
TB 746-10	Field Instructions for Painting and Preserving Electronics Command Equipment
TM 11-6625-274-12	Operator's and Organizational Maintenance Manual: Test Sets, Electron Tube TV-7/U, TV-7A/U, TV-7B/U, and TV-7D/U.
TM 11-6625-316-12	Operator and Organizational Maintenance Manual: Test Sets, Electron Tube TV-2/U, TV-2A/U, TV-2B/U, and TV-2C/U.
TM 11-6625-320-12	Operator and Organization Maintenance Manual: Voltmeter, Meter ME-30A/U, and Voltmeters, Electronic ME-30B/U, ME-30C/U, and ME-30E/U.
TM 11-6625-438-15	Organizational, DS, GS, and Depot Maintenance Manual: Voltmeter, Electronic AN/USM-98.
TM 11-6625-683-15	Operator, Organizational, DS, GS, and Depot Maintenance Manual: Signal Generator AN/URM-127.
TM 11-6625-700-10	Operator's Manual: Digital Readout, Electronic Counter AN/USM-207.
TM 11-6625-1703-15	Operator, Organizational, DS, GS, and Depot Maintenance Manual Including Repair Parts and Special Tools Lists: Oscilloscope AN/USM-281A.
TM 38-750	The Army Maintenance Management System (TAMMS).

APPENDIX C

MAINTENANCE ALLOCATION

Section I. INTRODUCTION

C-1. General

This appendix provides a summary of the maintenance operations for SG-299(*)/U. It authorizes categories of maintenance for specific maintenance functions on repairable items and components and the tools and equipment required to perform each function. This appendix may be used as an aid in planning maintenance operations.

C-2. Maintenance Function

Maintenance functions will be limited to and defined as follows:

a. Inspect. To determine the serviceability of an item by comparing its physical, mechanical, and/or electrical characteristics with established standards through examination.

b. Test. To verify serviceability and to detect incipient failure by measuring the mechanical or electrical characteristics of an item and comparing those characteristics with prescribed standards.

c. Service. Operations required periodically to keep an item in proper operation condition; i.e., to clean, preserve, drain, paint, or to replenish fuel/lubricants/hydraulic fluids or compressed air supplies.

d. Adjust. Maintain within prescribed limits by bringing into proper or exact position, or by setting the operating characteristics to the specified parameters.

e. Align. To adjust specified variable elements of an item to about optimum or desired performance.

f. Calibrate. To determine and cause corrections to be made or to be adjusted on instruments or test measuring and diagnostic equipment used in precision measurement. Consists of the comparison of two instruments, one of which is a certified standard of known accuracy, to detect and adjust any discrepancy in the accuracy of the instrument being compared.

g. Install. The act of emplacing, seating, or fixing into position an item, part, module (component or assembly) in a manner to allow the proper functioning of the equipment/system.

h. Replace. The act of substituting a ser-

viceable like-type part, subassembly, model (component or assembly) for an unserviceable counterpart.

i. Repair. The application of maintenance services (inspect, test, service, adjust, align, calibrate, replace) or other maintenance actions (welding, grinding, riveting, straightening, facing, remachining, or resurfacing) to restore serviceability to an item by correcting specific damage, fault, malfunction, or failure in a part, subassembly, module/component/assembly, end item or system.

j. Overhaul. That periodic maintenance effort (service/action) necessary to restore an item to a completely serviceable/operational condition as prescribed by maintenance standards (e.g., D W R) in appropriate technical publications. Overhaul is normally the highest degree of maintenance performed by the Army. Overhaul does not normally return an item to like-new condition.

k. Rebuild. Consists of those services/actions necessary for the restoration of unserviceable equipment to a like-new condition in accordance with original manufacturing standards. Rebuild is the highest degree of materiel maintenance applied to Army equipment. The rebuild operation includes the act of returning to zero those age measurements (hours, miles, etc.) considered in classifying Army equipment/components.

C -3. Column Entries

a. Column 1, Group Number. Column 1 lists group numbers, the purpose of which is to identify components, assemblies, subassemblies and modules with the next higher assembly.

b. Column 2, Component/Assembly. Column 2 contains the noun names of components, assemblies, subassemblies, and modules for which maintenance is authorized.

c. Column 3, Maintenance Functions. Column 3 lists the functions to be performed on the item listed in column 2.

d. Column 4, Maintenance Category. Column 4 specified, by the listing of a "worktime" figure in the appropriate sub column(s), the lowest level of

maintenance authorized to perform the function listed in column 3. This figure represents the active time required to perform that maintenance function at the indicated category of maintenance. If the number or complexity of the tasks within the listed maintenance function vary at different maintenance categories, appropriate "worktime" figures will be shown for each category. The number of man-hours specified by the "worktime" figure represents the average time required to restore an item (assembly, subassembly, component, module, end item or system) to a serviceable condition under typical field operating conditions. This time includes preparation time, troubleshooting time and quality assurance/quality control time in addition to the time required to perform the specific tasks identified for the maintenance functions authorized in the maintenance allocation chart, Sub columns of column 4 are as follows:

- C - Operator/Crew
- O- Organizational
- F- Direct Support
- H- General Support
- D- Depot

e. *Column 5, Tools and Equipment.* Column 5

specifies by code, those common tool sets (not individual tools) and special tools, test, and support equipment required to perform the designated function.

C-4. Tool and Test Equipment Requirements (Table I)

a. *Tool or Test Equipment Reference Code.* The numbers in this column coincide with the numbers used in the tools and equipment column of the MAC. The numbers indicate the applicable tool or test equipment for the maintenance functions.

b. *Maintenance Category.* The codes in this column indicate the maintenance category allocated the tool or test equipment.

c. *Nomenclature.* This column lists the noun name and nomenclature of the tools and test equipment required to perform the maintenance functions.

d. *National/NATO Stock Number.* This column lists the National/NATO stock number of the specific tool or test equipment.

e. *Tool Number.* This column lists the manufacturer's part number of the tool followed by the Federal Supply Code for manufacturers (5-digit) in parentheses.

(Next printed page is C-3)

SECTION II, MAINTENANCE ALLOCATION CHART
 FOR
 SIGNAL GENERATOR SG-299(*)U

(1) GROUP NUMBER	(2) COMPONENT/ASSEMBLY	(3) MAINTENANCE FUNCTION	(4) MAINTENANCE CATEGORY				(5) TOOLS AND EQUIPMENT	
				o	F	H		o
	GENERATOR SIGNAL SG-299 (*)U	Inspect		0.5				4, 10, 11
		Inspect				0.5		1 thru 9
		Inspect					0.5	1 thru 9
		Test		1.5				4, 10, 11
		Test				1.5		1 thru 9
		Test					1.5	1 thru 9
		Service		0.8				4, 10, 11
		Adjust				1.5		1 thru 9
		Adjust					1.5	1 thru 9
		Align				1.5		1 thru 9
		Align					1.5	1 thru 9
		Calibrate				2.0		1 thru 9
		Calibrate					2.0	1 thru 9
		Install		0.5				4, 10, 11
		Replace		1.0				4, 10, 11
		Replace				1.0		1 thru 9
		Replace					1.0	1 thru 9
		Repair				3.0		1 thru 9
		Repair					3.0	1 thru 9
		Overhaul				3.0		1 thru 9
		Overhaul					3.0	1 thru 9
		Rebuild					30	1 thru 9

TABLE I. TOOL AND TEST EQUIPMENT REQUIREMENTS FOR SIGNAL GENERATOR SG-299(*)/U

COLOR TEST EQUIPMENT REF CODE	MAINTENANCE CATEGORY	NOMENCLATURE	NATIONAL/NATO STOCK NUMBER	TOOL NUMBER
1	H, D	OSCILLOSCOPE, AN/USM-281	6625-00-053-3112	
2	H, D	COUNTER, ELECTRONIC DIGITAL READOUT, AN/USM-207	6625 -00-911-6368	
3	H, D	AUDIO OSCILLATOR , AN/URM-127	6625-00-783-5965	
4	O, H, D	MULTIMETER , AN/USM-223	6625-00-999-7465	
5	H, D	VOLTMETER, ELECTRONIC, ME-30 (*)/U	6625-00-669-0742	
6	H, D	VOLTMETER , ELECTRONIC , AN/USM-98	6625-00-753-2115	
7	H, D	TRANSFORMER, VARIABLE POWER, CN-16/U	5950-00-235-2o86	
8	H, D	TOOL KIT, RADAR AND RADIO REPAIR, TK-100/G	5180-00-605-0079	
9	H, D	TEST SET, ELECTRON TUBE, TV-2/U	6625-00-699-0263	
10	0	TEST SET, ELECTRON TUBE, TV-7/U	6625-00-820-0064	
11	0	TOOL KIT, RADAR AND RADIO REPAIR, TK-101/G	5180-00-064-5178	

INDEX

	Paragraph	Page	Paragraph	Page
Additional equipment required.	1-10	1-2	Localizing troubles.	6-7 6-5
Amplifier:			Lubrication.	4-9 4-3
Clipper.	5-2c, 5-6	5-3,5-7	Maintenance:	
Power.	5-2d, 5-7a	5-3,5-8	External synchronization	
Circuitry:			sensitivity adjustment.	6-14 6-26
Clipper amplifiers.	5-2c	5-3	frequency range adjustment.	6-13 6-24
Plate-coupled multivibrator.	5-2b	5-3	General.	6-10 6-21
Power amplifier.	5-2d	5-3	Power supply adjustments.	6-12 6-22
Power supply.	5-2g	5-3	Power transformer conversion.	6-15 6-27
75-ohm output.	5-2e	5-3	Replacement of parts.	6-11 6-22
600-ohm output.	5-2f	5-3	Modification work orders.	6-18 6-28
Sync trigger.	5-2a	5-3	Monthly preventive maintenance	
Cleaning.	4-8	4-3	checks and services.	4-7b 4-1
Clipper amplifiers.	5-2c, 5-6	5-3,5-7	Multivibrator.	5-3 5-3
Daily preventive maintenance			Operating Procedure.	3-5 3-3
checks and services.	4-7a	4-1	Operation in Arctic climates.	3-7 3-5
Demolition to prevent			Operation in desert climates.	3-9 3-5
enemy use.	1-6	1-1	Operation in tropical climates.	3-8 3-5
Description.	1-8	1-1	Operator controls.	3-2 3-1
Differences in models.	1-11	1-2	Operator's maintenance, scope of.	4-5 4-1
Equipment required.	1-10	1-2	Organization of trouble-	
External synchronization			shooting procedures.	6-5 6-1
sensitivity adjustment.	6-14	6-26	output:	
Externally synchronized			75-ohm.	5-2e 5-3
operation.	3-5b	3-4	600-ohm.	5-2f 5-3
Forms and records:			Painting.	4-10 4-4
Administrative storage.	1-5	1-1	Physical tests and inspections.	6-18 6-28
Discrepancy in			Placement of equipment.	2-3 2-2
shipment report.	1-3c	1-1	Plate-coupled multivibrator.	5-2b 5-3
Maintenance and unsatisfactory			Power amplifier.	5-2d, 5-7a 5-3,5-8
equipment, reports of.	1-3a	1-1	Power supply.	5-2g, 5-8 5-3,5-10
Packaging and handling			Power supply adjustment.	6-12 6-22
deficiencies, report of.	1-3b	1-1	Power transformer conversion.	6-15 6-27
Reporting of equipment			Preventive maintenance checks	
manual improvements.	1-4	1-1	and services.	4-4 4-1
Free running operation.	3-5a	3-3	Preventive maintenance checks	
Frequency range adjustment.	6-13	6-24	and services periods.	4-7 4-1
Functioning of equipment.	5-1	5-1	Publications, indexes of.	1-2 1-1
General support testing procedures:			Purpose and use.	1-7 1-1
External synchronization test.	6-25	6-39	RANGE switch.	5-4 5-5
Frequency range tracking test.	6-26	6-41	Repairs.	4-13 4-7
General information.	6-17	6-27	Replacement:	
High impedance output			Fuse.	4-13b 4-7
voltage test.	6-23	6-35	Parts.	6-11 6-22
Low impedance output			Pilot lamp.	4-13a 4-7
attenuation test.	6-24	6-37	Resistance of transformers	
Low impedance output			and coils.	6-9 6-21
voltage test.	6-22	6-33	Scope of operator's	
Modification work orders.	6-18	6-28	maintenance.	4-5 4-1
Output amplitude, line			Seventy-five ohm ATTEN switch.	5-7b 5-9
voltage variation test.	6-27	6-45	Short circuits, checks for.	6-6 6-5
Output frequency, line			Starting procedure.	3-4 3-3
voltage variation test.	6-28	6-27	Stopping procedure.	3-6 3-5
Physical tests and adjustments.	6-20	6-28	Sync trigger.	5-5 5-6
Symmetry test.	6-21	6-31	Systematic care.	4-6 4-1
Test data summary.	6-29	6-47	Tabulated data.	1-12 1-2
Test equipment required.	6-19	6-28	Tests:	
Impedance matching operation.	3-5c	3-4	External synchronization.	6-25 6-39
Indexes of publication.	1-2	1-1	Frequency range tracking.	6-26 6-41
Isolating techniques.	6-8	6-21	High impedance output voltage.	6-23 6-35

	Paragraph	Page		Paragraph	Page
Tets-Continued					
Low impedance output			Troubleshooting:		
attenuation.	6-24	6-37	General information.	4-11	4-4
Low impedance output voltage.	6-22	6-33	Isolating techniques.	6-8	6-21
Output amplitude, line			Localizing troubles.	6-7	6-5
voltage variation.	6-27	6-45	Organization of procedures.	6-5	6-1
Output frequency, line			Tube testing:		
voltage variation	6-28	6-47	Adjustment following replacement.	4-12c	4-6
Symmetry.	6-21	6-31	Substitution method.	4-12b	4-6
Teat data summary.	6-29	6-47	Use of tube tester.	4-12a	4-4
Teat equipment required:			Types of operation.	3-3	3-3
General support testing.	6-19	6-28	Unpacking.	2-1	2-1
Repair and alinement.	6-3	6-1			
Troubleshooting.	6-3	6-1			

By Order of the Secretary of the Army:

Official:
VERNE L. BOWERS
*Major General, United States Army,
 The Adjutant General.*

FRED C. WEYAND
*General, United States Army,
 chief of Staff.*

Distribution:

Active Army:

USASA (2)	ATS (1)
<i>Dir of Trans</i> (1)	MAAG (1)
COE (1)	WRAMC (1)
TSG (1)	USARMIS (1)
USAARENBD (1)	USAERDAA (1)
AMC (1)	USAERDAW (1)
MICOM (2)	Sig FLDMS (1)
TECOM (2)	Redstone Arsenal (2)
TRADOC (2)	Units org under fol TOE (1 ea.):
ARADCOM (2)	7
ARADCOM Rgn (2)	11-16
OS Maj Cored (4)	11-97
LOGCOMD (3)	11-117
USACC (4)	11-500 (AA-Ac)
USACC-CONUS (2)	17
MDW (1)	29-1
Armies (2)	29-1 1
Corps (2)	29-15
HISA (Ft Monmouth) (43)	29-16
Ft Gillem (10)	29-21
Ft Gordon (10)	29-25
Ft Huachuca (10)	29-35
Ft Carson (5)	29-36
Ft Richardson (ECOM Ofc) (2)	29-56
WSMR (1)	29-134
svc Colleges (1)	29-136
USASESS (5)	37
USAINTCS (3)	44-235
USAADS (2)	44-236
USAFAS (2)	44-237
USAARMS (2)	44-568
USAIS (2)	
USAES (2)	
AD (II except	
SAAD (30)	
LABD (14)	
TOAD (14)	
USA Dep (2)	
Sig Sec USA Dep (2)	
Sig Dep (2)	

ARNG: State AG (3).

USAR: None.

For explanation of abbreviations used, see AR 310-50.

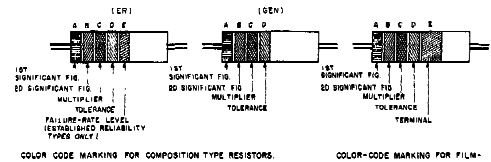

COLOR CODE MARKING FOR COMPOSITION TYPE RESISTORS. COLOR-CODE MARKING FOR FILM-TYPE RESISTORS.

TABLE 1
COLOR CODE FOR COMPOSITION TYPE AND FILM TYPE RESISTORS.

BAND A	BAND B	BAND C	BAND D	BAND E
FIRST SIGNIFICANT FIGURE	SECOND SIGNIFICANT FIGURE	COLOR	MULTIPLIER	RESISTANCE TOLERANCE (PERCENT)
BLACK	0	BLACK	1	BROWN
BROWN	1	BROWN	10	RED
RED	2	RED	100	ORANGE
ORANGE	3	ORANGE	1,000	YELLOW
YELLOW	4	YELLOW	10,000	GREEN
GREEN	5	GREEN	100,000	BLUE
BLUE	6	BLUE	1,000,000	PURPLE (VIOLET)
PURPLE (VIOLET)	7	PURPLE (VIOLET)	10,000,000	GRAY
GRAY	8	GRAY	100,000,000	WHITE
WHITE	9	WHITE	1,000,000,000	

BAND A — THE FIRST SIGNIFICANT FIGURE OF THE RESISTANCE VALUE (BANDS A THRU D SHALL BE OF EQUAL WIDTH).

BAND B — THE SECOND SIGNIFICANT FIGURE OF THE RESISTANCE VALUE.

BAND C — THE MULTIPLIER (THE MULTIPLIER IS THE FACTOR BY WHICH THE TWO SIGNIFICANT FIGURES ARE MULTIPLIED TO YIELD THE NOMINAL RESISTANCE VALUE).

BAND D — THE RESISTANCE TOLERANCE.

BAND E — WHEN USED ON COMPOSITION RESISTORS, BAND E INDICATES ESTABLISHED RELIABILITY FAILURE-RATE LEVEL; PERCENT FAILURE PER 1,000 HOURS) ON FILM RESISTORS, THIS BAND SHALL BE APPROXIMATELY 1-1/2 TIMES THE WIDTH OF OTHER BANDS, AND INDICATES TYPE OF TERMINAL.

RESISTANCES IDENTIFIED BY NUMBERS AND LETTERS (THREE ARE NOT COLOR CODED).

SOME RESISTORS ARE IDENTIFIED BY THREE OR FOUR DIGIT ALPHA NUMERIC DESIGNATORS. THE LETTER R IS USED IN PLACE OF A DECIMAL POINT WHEN FRACTIONAL VALUES OF AN OHM ARE EXPRESSED. FOR EXAMPLE:

ERT = 2.7 OHMS 10R = 10.0 OHMS

FOR WIRE-WOUND-TYPE RESISTORS COLOR CODING IS NOT USED, IDENTIFICATION MARKING IS SPECIFIED IN EACH OF THE APPLICABLE SPECIFICATIONS.

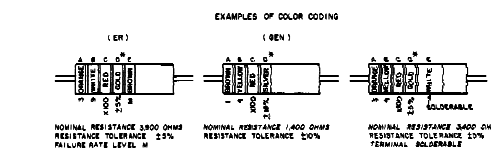

A. COLOR CODE MARKING FOR MILITARY STANDARD RESISTORS. B. COLOR CODE MARKING FOR MILITARY STANDARD INDUCTORS.

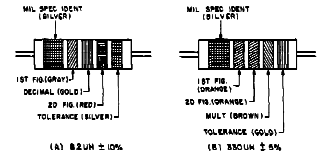

COLOR CODING FOR TUBULAR ENCAPSULATED R.F. CHOKES. AT A, AN EXAMPLE OF THE CODING FOR AN 82UH CHOKER IS GIVEN. AT B, THE COLOR BANDS FOR A 330UH INDUCTOR ARE ILLUSTRATED.

TABLE 2
COLOR CODING FOR TUBULAR ENCAPSULATED R.F. CHOKES.

COLOR	SIGNIFICANT FIGURE	MULTIPLIER	INDUCTANCE TOLERANCE (PERCENT)
BLACK	0	1	
BROWN	1	10	
RED	2	100	
ORANGE	3	1,000	
YELLOW	4		
GREEN	5		
BLUE	6		
PURPLE (VIOLET)	7		
GRAY	8		
WHITE	9		
SILVER		80	
GOLD		10	
		DECIMAL POINT	

MULTIPLIER IS THE FACTOR BY WHICH THE TWO COLOR FIGURES ARE MULTIPLIED TO OBTAIN THE INDUCTANCE VALUE OF THE CHOKER COIL.

CAPACITORS, FIXED, VARIOUS-DIELECTRICS, STYLES CM, CN, CY, AND CB.

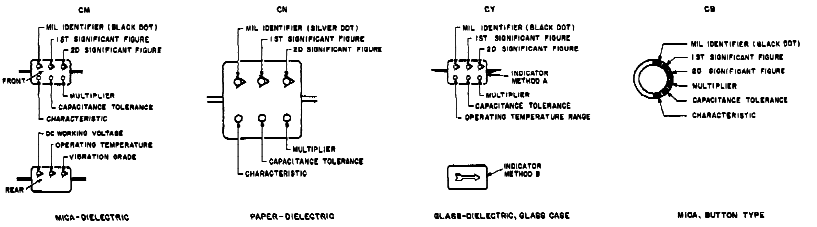

MICA-DIELECTRIC PAPER-DIELECTRIC GLASS-DIELECTRIC, GLASS CASE MICA, BUTTON TYPE

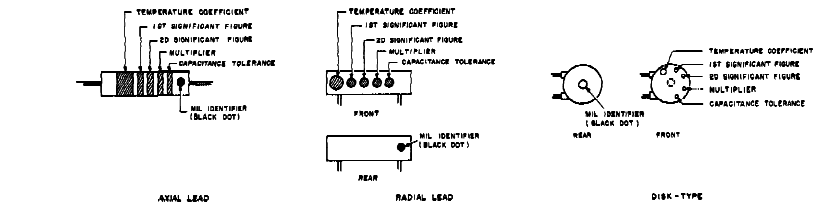

C. COLOR CODE MARKING FOR MILITARY STANDARD CAPACITORS.

TABLE 3 — FOR USE WITH STYLES CM, CN, CY AND CB.

COLOR	MIL ID	1ST FIG	2D FIG	MULTIPLIER	CAPACITANCE TOLERANCE				CHARACTERISTIC	DC WORKING VOLTAGE	TEMP. RANGE	OPERATIVE VIBRATION GRADE
					CM	CN	CY	CB				
BLACK	0	0	0	1	±20%	±20%			A	E	B	10-56 Hz
BROWN	1	1	1	10					B	E	B	10-56 Hz
RED	2	2	2	100	±1%	±2%	±5%	±10%	C			10-56 Hz
ORANGE	3	3	3	1,000	±1%	±2%	±5%	±10%	D	B	B	10-56 Hz
YELLOW	4	4	4	10,000	±1%	±2%	±5%	±10%	E	B	B	10-56 Hz
GREEN	5	5	5						F			10-56 Hz
BLUE	6	6	6									10-56 Hz
PURPLE (VIOLET)	7	7	7									10-56 Hz
GRAY	8	8	8									10-56 Hz
WHITE	9	9	9									10-56 Hz
GOLD				0.1	±5%	±5%						10-56 Hz
SILVER	00			0.01	±10%	±10%	±10%	±10%				10-56 Hz

TABLE 4 — TEMPERATURE COMPENSATING, STYLE CC.

COLOR	TEMPERATURE COEFFICIENT	1ST FIG	2D FIG	MULTIPLIER	CAPACITANCE TOLERANCE		MIL ID
					OVER 10 UUF	10 UUF OR LESS	
BLACK	0	0	0	1			CC
BROWN	-90	1	1	10	±1%		
RED	-80	2	2	100	±2%	±0.25 UUF	
ORANGE	-80	3	3	1,000			
YELLOW	-80	4	4				
GREEN	-80	5	5		±5%	±0.5 UUF	
BLUE	-40	6	6				
PURPLE (VIOLET)	-70	7	7				
GRAY	0	8	8	0.1*			
WHITE	0	9	9	0.1*	±10%		
GOLD	+100			0.1		±1.0 UUF	
SILVER				0.01			

1. THE MULTIPLIER IS THE NUMBER BY WHICH THE TWO SIGNIFICANT (516) FIGURES ARE MULTIPLIED TO OBTAIN THE CAPACITANCE IN UUF.
2. LETTERS INDICATE THE CHARACTERISTICS DESIGNATED IN APPLICABLE SPECIFICATIONS: MIL-C-50, MIL-C-500, MIL-C-112E2B, AND MIL-C-1060C RESPECTIVELY.
3. LETTERS INDICATE THE TEMPERATURE RANGE AND VOLTAGE-TEMPERATURE LIMITS DESIGNATED IN MIL-C-112E2B.
4. TEMPERATURE COEFFICIENT IN PARTS PER MILLION PER DEGREE CENTIGRADE.
5. *OPTIMAL CODING WHERE METALLIC ELEMENTS ARE UNDESIRABLE.

Figure FO-1. Color code marking for MIL-STD resistors, inductors, and capacitors.

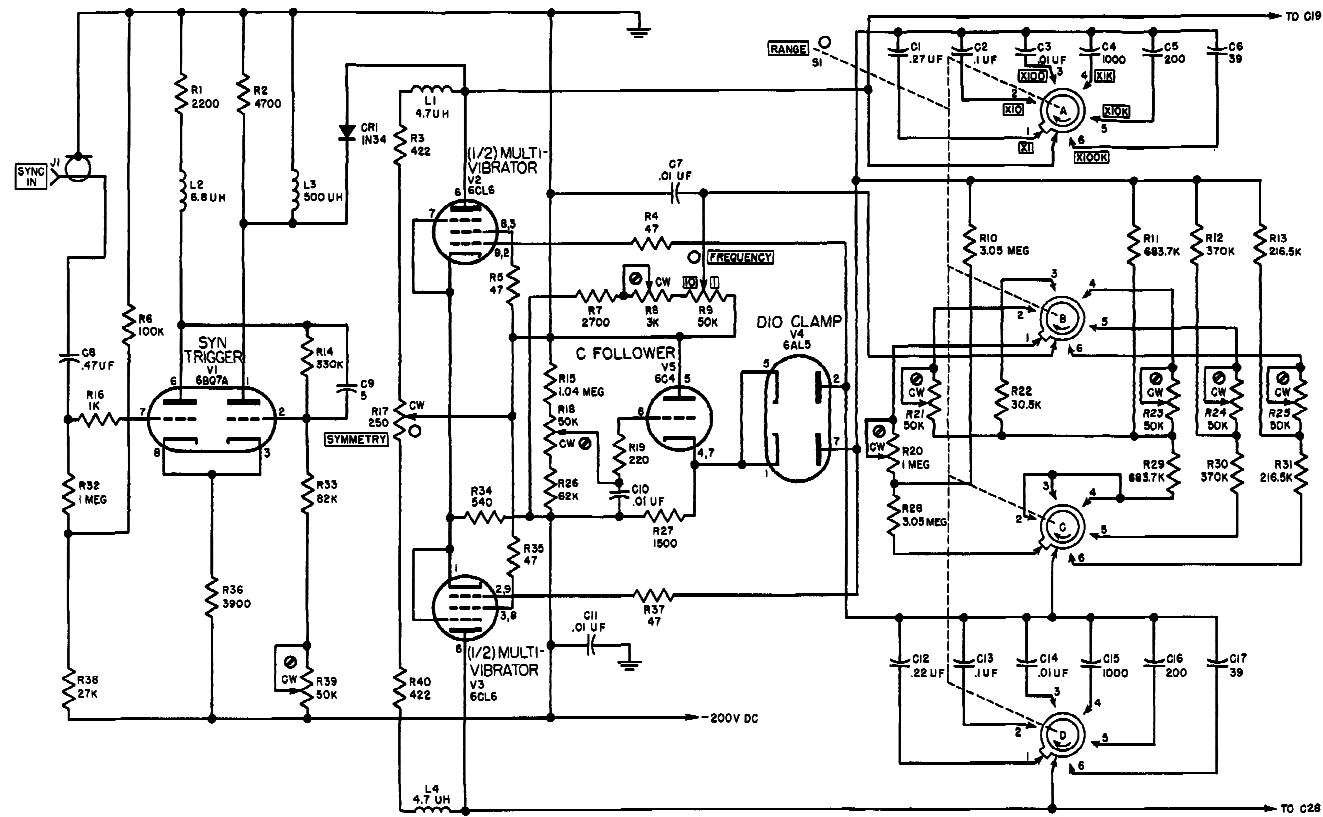

- NOTES:
1. UNLESS OTHERWISE INDICATED, RESISTANCES ARE IN OHMS, CAPACITANCES ARE IN U.F.
 2. INDICATES EQUIPMENT PANEL MARKING
 PANEL CONTROL
 SCREWDRIVER ADJUST
 3. SWITCH SECTIONS ARE SHOWN IN COUNTERCLOCKWISE POSITION AS VIEWED FROM KNOB END. SECTION 'A' CLOSEST TO KNOB.
 4. IN THE A, B, C, AND D MODELS, CRI IS TYPE 1N69A, C1 IS .22UF.
 5. IN THE A MODEL, R9 IS 5K, R26 IS 90.5K.
 6. IN THE B AND D MODELS, R26 IS 82K.
 7. IN THE C MODEL AND THE A MODEL SUPPLIED ON ORDER NO. 4502-PP-60, R11 AND R29 ARE 684K, R15 IS 1.03 MEG, AND R13 AND R31 ARE 216K.

Figure FO-2. Signal generator, sync trigger and multivibrator, schematic diagram.

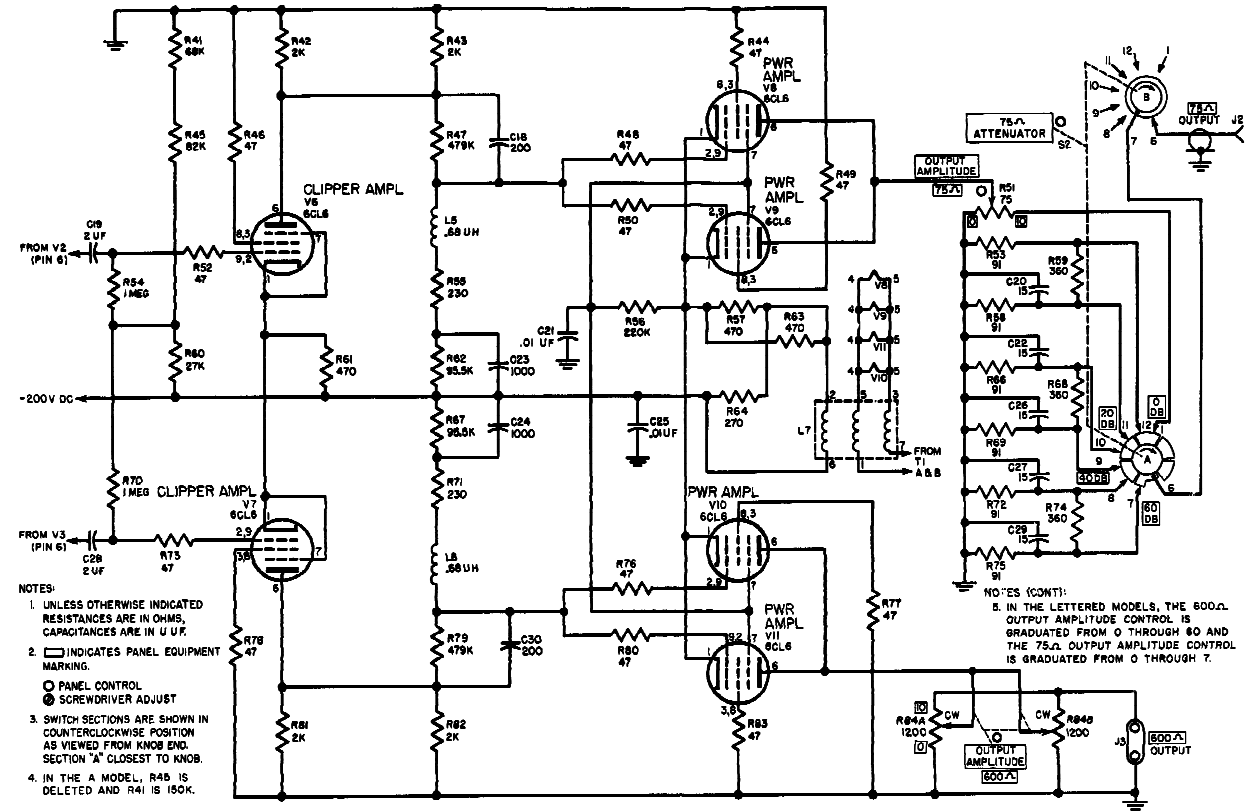

NOTES:

1. UNLESS OTHERWISE INDICATED RESISTANCES ARE IN OHMS, CAPACITANCES ARE IN U.F.
2. INDICATES PANEL EQUIPMENT MARKING.
3. PANEL CONTROL. SCREWDRIVER ADJUST.
4. IN THE A MODEL, R45 IS DELETED AND R41 IS 180K.

NOTES (CONT):

5. IN THE LETTERED MODELS, THE 800Ω OUTPUT AMPLITUDE CONTROL IS GRADUATED FROM 0 THROUGH 60 AND THE 75Ω OUTPUT AMPLITUDE CONTROL IS GRADUATED FROM 0 THROUGH 7.

Figure FO-3. Signal generator, amplifier stages, schematic diagram.

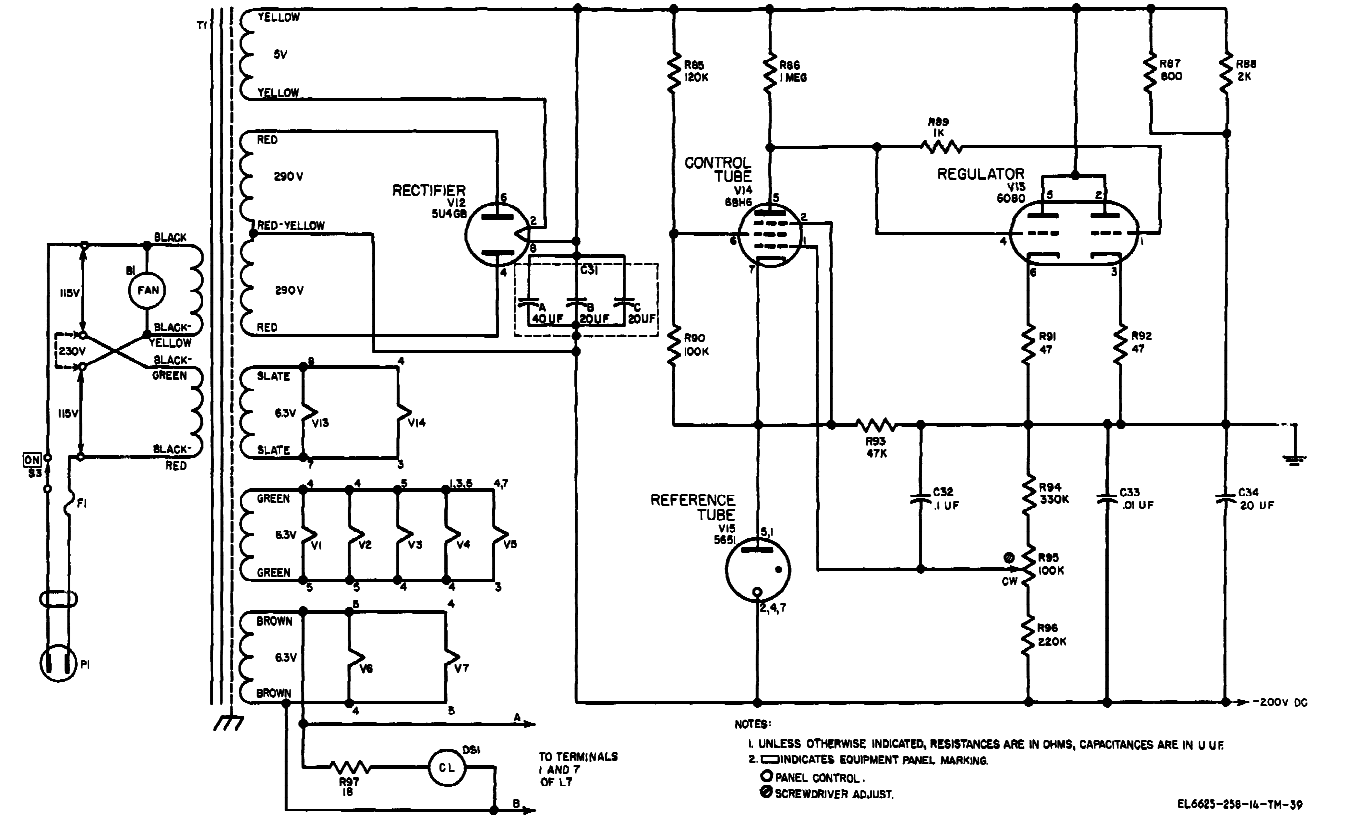

Figure FO-4. Signal Generator (SG-299/U, power supply, schematic daigram.

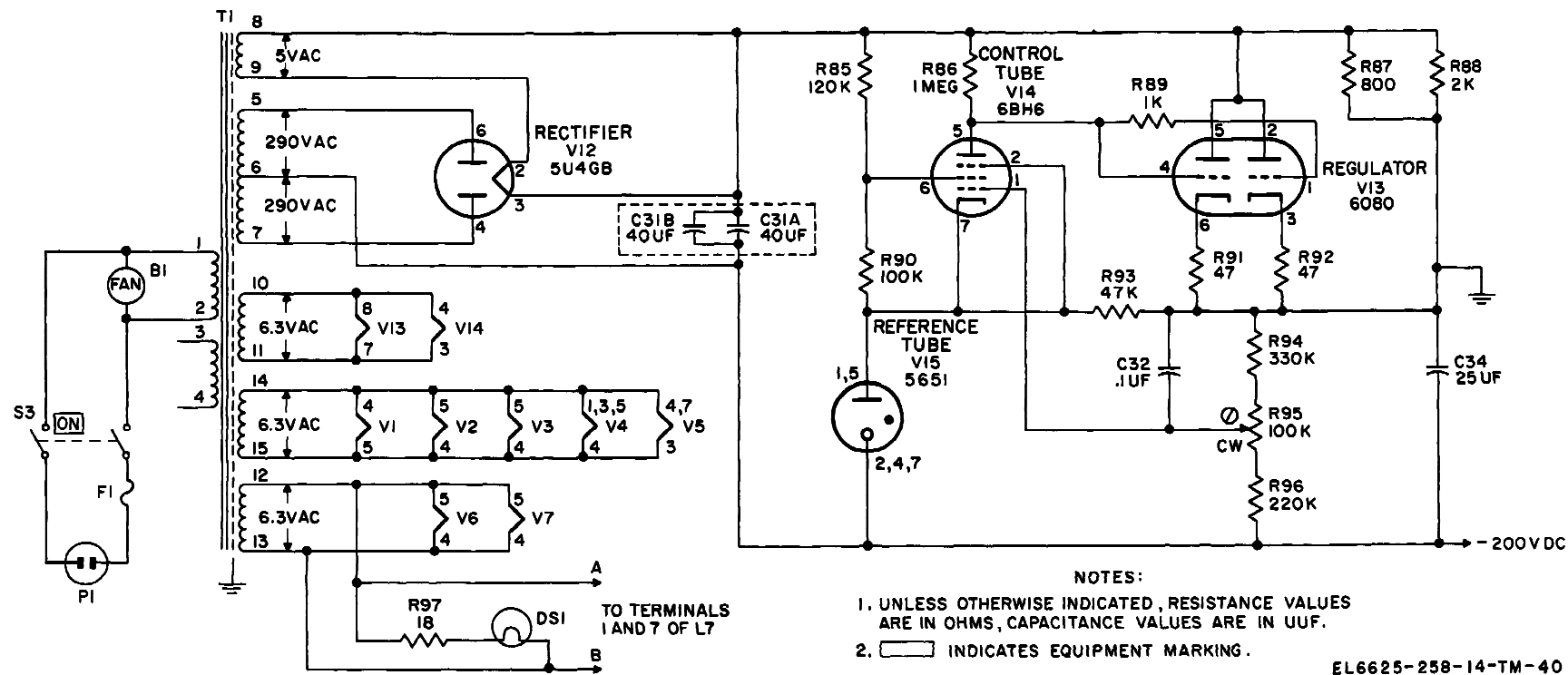
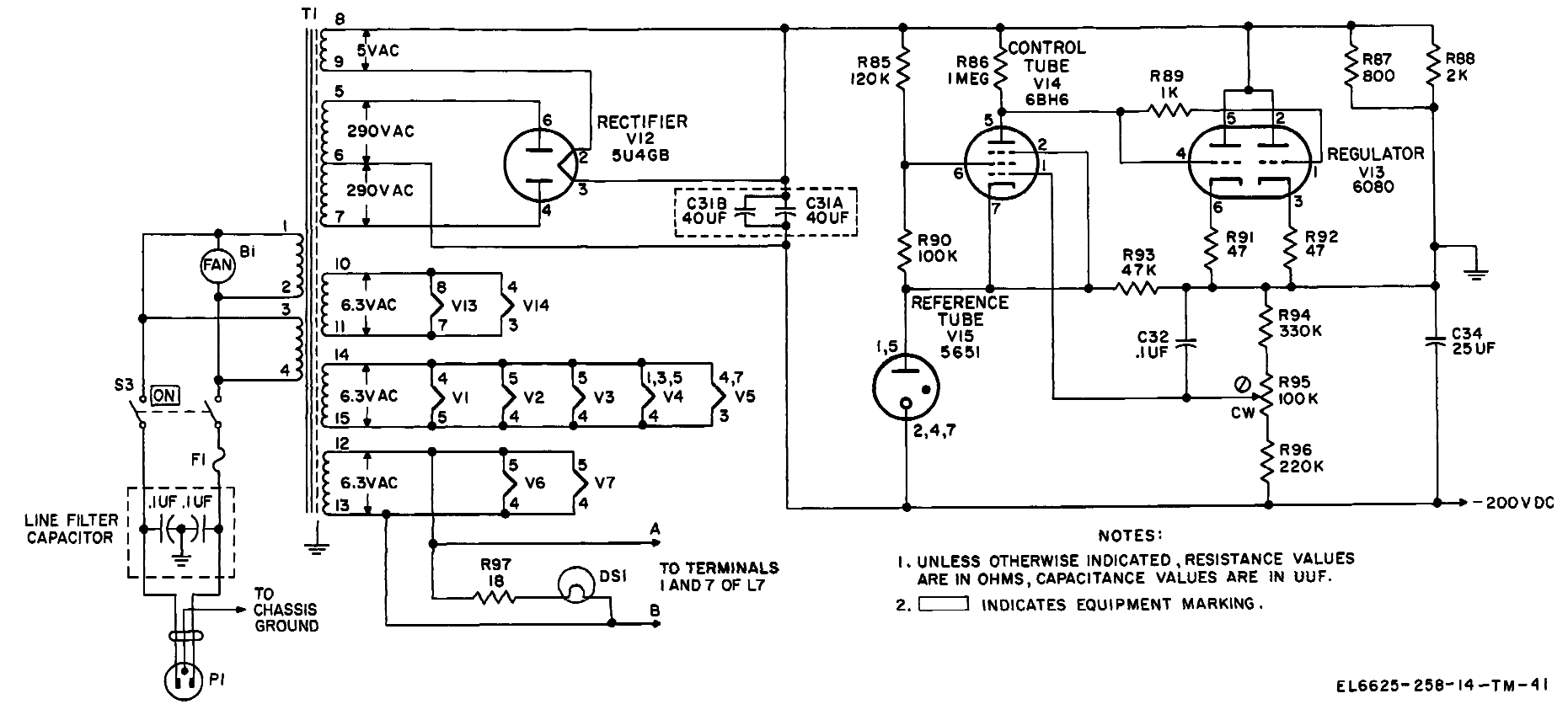

Figure FO-5. Signal Generator SG-299AU, power supply, schematic diagram.



EL6625-258-14-TM-41

Figure FO-6. Signal Generator SG-299B/U, SG-299C/U, SG-299D/U, and SG-299E/U, power supply, schematic diagram.

DEPARTMENT OF THE ARMY
US ARMY AG PUBLICATIONS CENTER
1655 WOODSON ROAD
ST. LOUIS, MISSOURI 63114

OFFICIAL BUSINESS
PENALTY FOR PRIVATE USE \$300

POSTAGE AND FEES PAID
DEPARTMENT OF THE ARMY
DOD 314

